



# **WIO 300 and WIOI300 Water in oil sensor**

User manual Rev. 1.09

111881-940 Rev. 1.09 User manual 300

Date: 2017-01-20



## Table of contents

Table of contents .....	2
Introduction.....	3
Safety Advice .....	4
Function.....	6
Normal operation.....	7
Failure indication.....	8
Self test for alarm functions.....	9
Before installation.....	11
WIO Sensor dimensions in mm.....	15
Terminal box dimensions in mm.....	17
WIO Integrated (WIOI) dimensions in mm .....	18
Technical data, Sensors .....	20
Technical Data Terminal Box .....	23
Technical Data Terminal Display Box.....	25
Technical Data Terminal Box Alarm .....	28
Technical Data Terminal Box Alarm Buzzer.....	31
Technical Data Terminal Box Alarm Buzzer.....	35
Technical data, WIOI (WIO Integrated) .....	40
Communication protocol for Modbus on RS232 .....	46
Communication examples for function code 01.....	47
Communication examples for function code 03.....	47
Communication examples for function code 04.....	47
Communication examples for function code 05.....	48
Communication examples for function code 06.....	48
Communication examples for function code 10.....	48
CRC Calculation.....	49
Error codes .....	49
Table for aW to HEX value .....	50
WIO-Software .....	50
EC-Declaration of Conformity.....	51
Appendix A1: Install 1 Terminal Box with 1 display.....	54
Appendix A2: Install 1 Terminal Box with no display.....	55
Appendix A3: Install 2 Terminal Boxes with 3 display .....	56
Appendix A4: Install 2 Terminal Boxes with 1 display .....	57
Appendix A5: Install 2 Terminal Boxes with 2 display .....	58
Appendix A6: Install 3 Terminal Boxes with 4 display .....	59
Appendix A7: Install 3 Terminal Boxes with 3 display .....	60
Appendix A8: Install 3 Terminal Boxes with 2 display .....	61
Appendix A9: CABLE Specification.....	62
How to adjust the display in a WIO/WIOI.....	63
Appendix A10: Error / failure FAQ.....	71
Company Information.....	74



## Introduction

This user manual provides technical data regarding the WIO (water in lubrication oil, gear box oil, diesel oil, hydraulic oil or transformer oil) sensor system. The system consist of a WIO Sensor, terminal box and cables. The WIO Sensor is an insitu sensor which measures water content in lubrication oils on ship engine or similar. The Terminal box connects the sensor to power supply and to the ships surveillance system. The supplied cables are for connection between the WIO Sensor and the Terminal box





## Safety Advice

### For your safety

The *WIO300* (WIO) is designed as water in oil monitoring system, with a relay switch-off function and RS232 communication based on Modbus protocol.

Before use please read the user manual and carefully store it in a safe place. Install and operate the device only after reading and comprehending the instruction manual, and after you are familiar with the valid rules on work safety and accident prevention.

Please use the device only as specified. For this purpose please also note the values in section "Technical data".

During transport, storage and operation please adhere to the conditions listed in "Technical data".

### IMPORTANT

---

Only qualified personnel may assemble start-up and maintain the unit when it is in a zero voltage state. Only qualified electricians may work on electrical installations.

The connection and instruction manual contains information that enables the proper and efficient use of the WIO monitoring system. PAJ Sensors A/S is not liable for damage caused by improper use of this device. This manual is an integral part of the basic knowledge necessary for proper use of the system.

### Rights

---

PAJ Sensors A/S reserves the right to alter its products without prior notice.

Copying and using the instruction manual for other purposes is only allowed with the acceptance from PAJ Sensors A/S.

PAJ Sensors A/S accepts no responsibility for possible errors and deficiencies in brochures, catalogues and other printed material.

PAJ Sensors A/S guarantees correct function as well as fulfillment of the safety requirements only when connections are made in accordance with instructions.



## **Safety observations**

---

The comments about safety in this document will not discuss safety observations of individual machine parts where safety devices (usually safety relays) are applied. Here the respective instruction manuals will be referenced! This document merely describes how to establish a WIO and how to start it up.

## **WARNING**

---

The monitoring system during machine operation cannot be guaranteed if the system is connected incorrectly or not used as specified. This may lead to fatal injuries. Interventions and changes to the WIO monitoring system are not permitted, unless they are explicitly described in this user manual or be written from PAJ Sensors A/S.

The regional legal regulations and conditions of the liability insurance of the employer must be maintained.

## **Area of application**

---

The WIO monitoring system is usually used in engines where a WIO will monitor the water content in lubrication oil, gear box oil, diesel oil, hydraulic oil or transformer oil.

The advantage of this monitoring system is the simple 4-20 mA interface and the two relays indicating alarms, with digital readout.

Normally the WIO sensor is calibrated in Taro30 lubrication oil, if nothing else are defined from customer.



## Function

### Short description of the function

PAJ Sensors A/S has developed a water in oil (WIO) monitoring system. The fundamental idea of the WIO system is to easily and continuously monitor the water activity ( $a_w$ ) in oil. The output is converted into a standard 4-20 mA output.

The system also includes two relays indicating when too much water is present in the oil. Default alarm values are set to 0,5  $a_w$  (high alarm) and 0,9  $a_w$  (high high alarm)

By use of the WIO-Software it is possible to change HHA and HA levels. Furthermore you can continuously read out and graph the  $a_w$  (or PPM) of water in the oil.

## WARNING

---

Do not use the sensor or relays to automatically enable/turn on or disable/shut down engine. The decision to enable/turn on or disable/shut down an engine, based on the sensor data, must be taken by proper trained crew personnel, not by the sensor system.



## Normal operation

Water activity ( $a_w$ ) provides the relative availability of water in oil where pure oil has an activity of zero and oil saturated with distilled water has an activity of exactly one. Under normal operation the WIO300 continuously supplies an output analogue signal of 4 to 20 mA corresponding to 0.01 to 1.00  $a_w$ . Alarm indications with 0.03  $a_w$  hysteresis via 2 relays are provided for each sensor. These data can also be read out from the sensor on the RS232 Modbus communication line.

Default alarm values are 0,5  $a_w$  and 0,9  $a_w$ . Assumes these alarm values:

High alarm on at 0,50  $a_w$  (12 mA).

High alarm off at 0,47  $a_w$  (11,5 mA)

High high alarm on at 0,90  $a_w$  (18,4 mA).

High high alarm off at 0,87  $a_w$  (17,9 mA).

High high alarm will disable high alarm, thus only one alarm can be active.

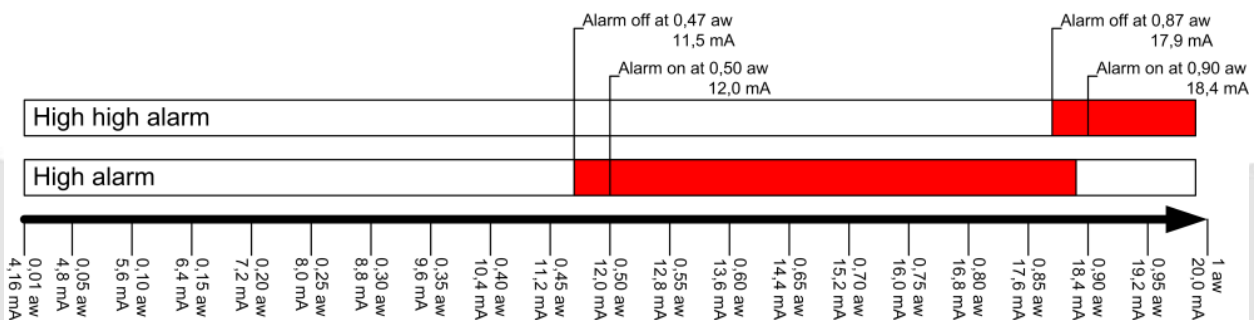



## Failure indication

Internal function failure will be indicated by activating both alarm relays at the same time, or indicated as defined in the NAMUR NE43.

Internal failures includes:

- Sensor reading out of range.
- Sensor reading CRC error.
- Unstable Sensor reading.

NAMUR NE43 is a German fault detection standard for 4-20mA analogue signals. It allows the user to know if there is a fault within the instrument, by sending analogue signal below 4mA and/or above 20mA. In accordance with NAMUR NE43, the failure is indicated by:

- Fault indicated by analogue output  $= < 2,0 \text{ mA}$





## Self test for alarm functions



On the WIO Sensor there is a button for testing the alarm functions. By pushing the Test button for 5 sec the high alarm relay turns on, and by pushing the Test button for 10 sec the high alarm relay turns off and the high high alarm turns on. When the Test button has been pushed continuously for more than 15 sec, it will be ignored by the software, and the relays return to normal operation.

<b>Test Button</b>	<b>Mode</b>	<b>Output Relay</b>	<b>Analogue Output</b>
Un-pressed	Normal operation and <b>no alarm</b>	Relay 1 Open Relay 2 Open	Normal
Pressed longer than <b>5 sec</b>	Test of high alarm	Relay 1 Closed Relay 2 Open	Normal
Pressed longer than <b>10 sec</b>	Test of high high alarm	Relay 1 Open Relay 2 Closed	Normal
Pressed longer than <b>15 sec</b>	Normal operation	Normal	Normal



<b>Test Button</b>	<b>Mode</b>	<b>Output Relay</b>	<b>Analogue Output</b>
Un-pressed	Normal operation, with <b>high alarm active</b>	Relay 1 Closed Relay 2 Open	Normal
Pressed longer than <b>5 sec</b>	Test of high alarm	Relay 1 Closed Relay 2 Open	Normal
Pressed longer than <b>10 sec</b>	Test of high high alarm	Relay 1 Open Relay 2 Closed	Normal
Pressed longer than <b>15 sec</b>	Normal operation	Normal	Normal



## ***Before installation***



### **IMPORTANT**

---

Only qualified personnel may assemble and maintain the unit. Only qualified personnel may install the unit.

Screw in probe pressure-tight directly in the center of the oil pipe where the measurement is to take place. The threads should be sealed with Loctite® 271. The sensor should be mounted with max. torque of 35 Nm. Connect the cables from the WIO sensor to the Terminal box. Use a hexagon wrench size 30.

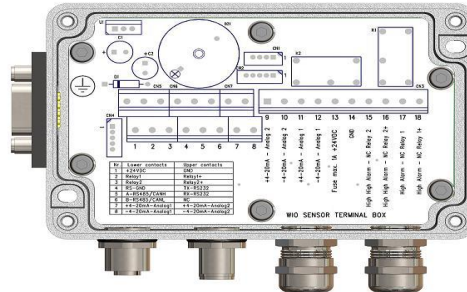

To sensor      Power and Alarms

## IMPORTANT

Only qualified personnel may assemble start-up and maintain the terminal box(s) when it is in a zero voltage state. Only qualified electricians may work on electrical installations.

Install +24 VDC and GND into the terminal box and connect the 4-20 mA to an external device if needed. Connect the relay to external device if needed.

If the terminal box has a (a<sub>w</sub>) or PPM display, there must be a short circuit between terminals 11 and 12. This short circuit produces the needed closed loop for mA measurement.

If the terminal box has a °C or °F display, there must be a short circuit between terminals 9 and 10. This short circuit produces the needed closed loop for mA measurement.

After installing the WIO-Software can PC and terminal box be connected through DB9 connector.

Last connect the cables from the Terminal box to the sensor.

It is allowed (but not necessary) to connect screw terminal 10 and 12 "4-20 mA" to screw terminal 14 "GND", thus creating common ground for the output and the power.

Terminal boxes with display. Screw terminal pin 11 and 12 or screw terminal pin 9 and 10 can be connected to external equipment, but only in a closed loop for mA measurement.

## Terminal Box Connection

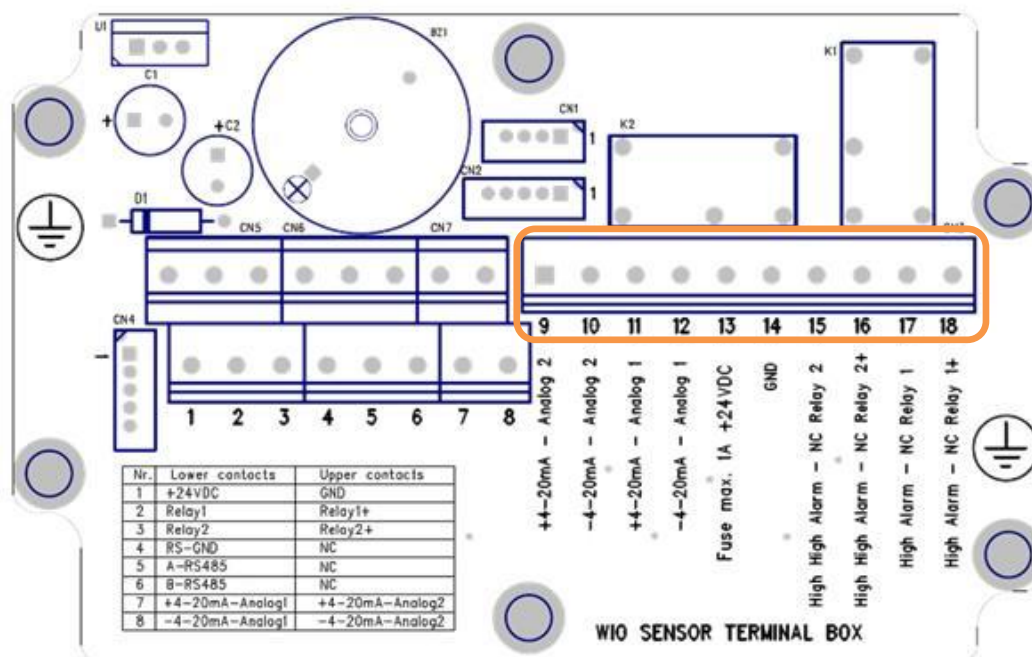

## Contact Assignment

There is only one connector **CN3** for using of the terminal box contacts.

Contact-Number	Description
9	+4 – 20 mA positive analog output signal for indication of temperature in oil. This option is not available for WIO200
10	-4 – 20 mA return analog signal for indication of temperature in oil. This option is not available for WIO200
11	+4 – 20 mA positive analog output signal for indication of $a_w$ or PPM in oil.
12	-4 – 20 mA return analog signal for indication of $a_w$ or PPM in oil.
13	Power supply, 24VDC $\pm$ 10% and with max. residual voltage ripple 10%
14	Power supply ground terminal contact
15	Relay contact for HH Alarm
16	Relay contact for HH Alarm
17	Relay contact for H Alarm
18	Relay contact for H Alarm

For connection more than one terminal box please refer to:

- Appendix A1
- Appendix A2
- Appendix A3



## Pin assignment of D-Sub9 connector

Communication

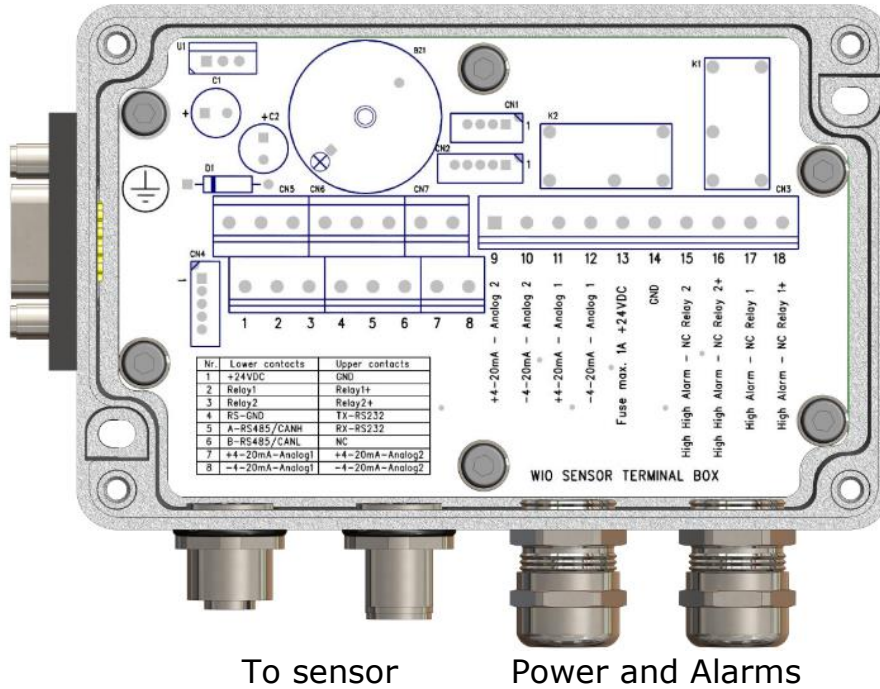

To sensor

Power and Alarms

DB9 connector pin layout			
Illustration		Assignment	
	1	NC	-
	2	Yellow	TX-RS232
	3	Green	RX-RS232
	4	NC	-
	5	Black	RS-GND
	6	NC	-
	7	NC	-
	8	NC	-
	9	NC	-

Max length of communication cable – 15 meters.



## WIO Sensor dimensions in mm

### WIO Standard 1/2" thread Sensor, Short dimensions in mm:

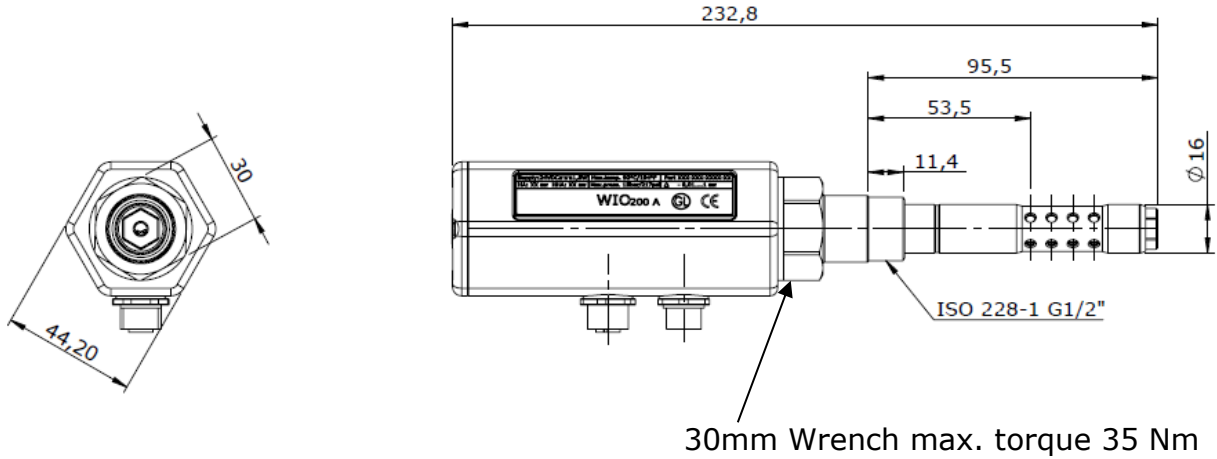

### WIO Standard 3/4" thread Sensor, Short dimensions in mm:

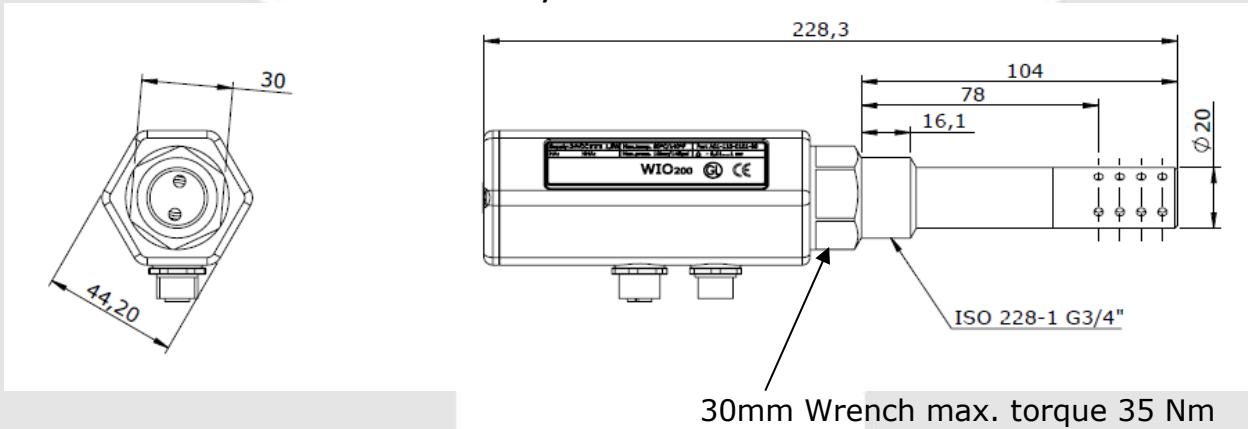



**WIO Ball Valve pipe 1/2" thread Sensor, Long dimensions in mm:**

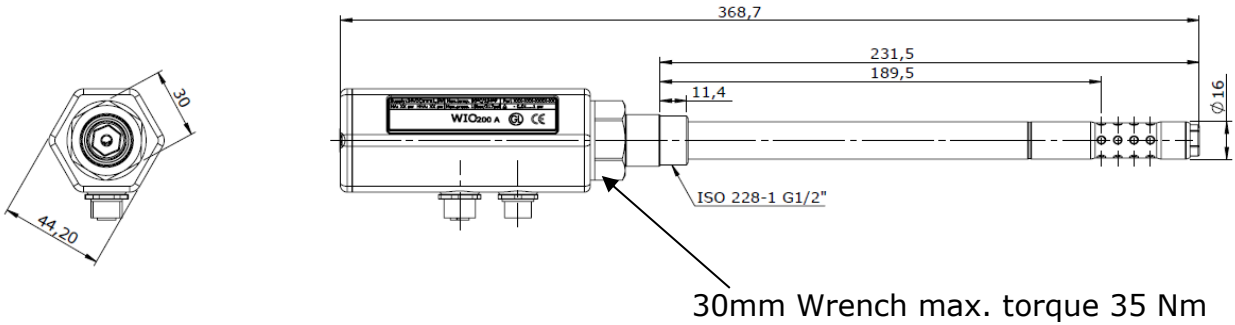

**WIO Ball Valve pipe 3/4" thread Sensor, Long dimensions in mm:**

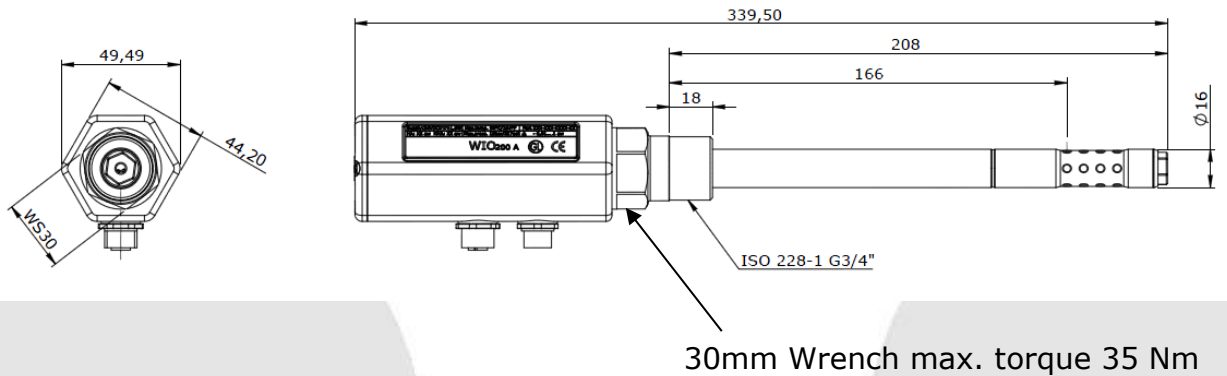





## Terminal box dimensions in mm

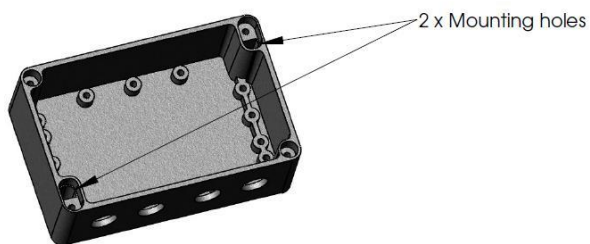
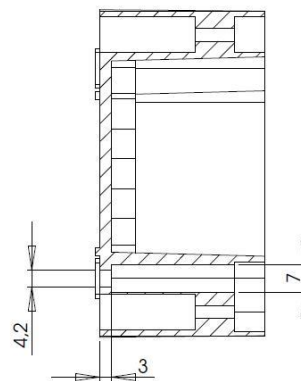
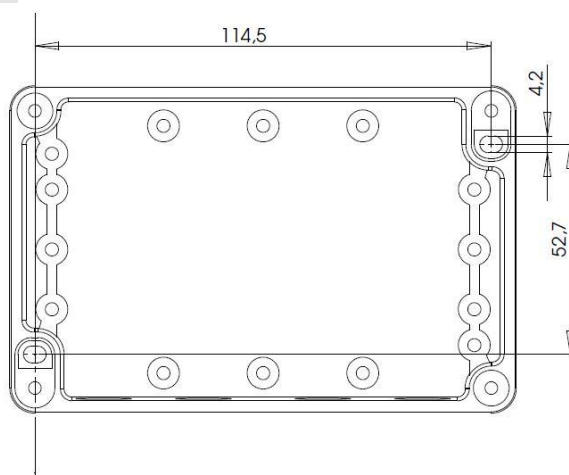
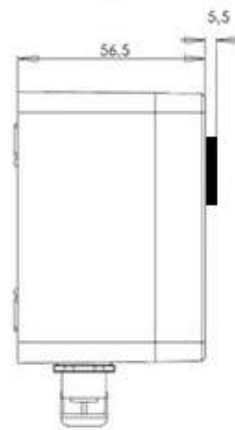
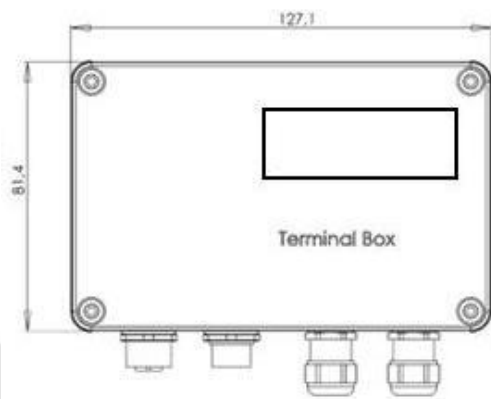
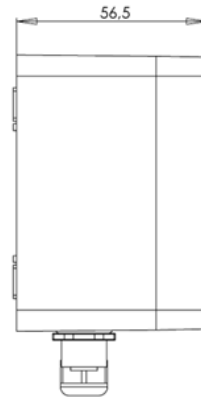
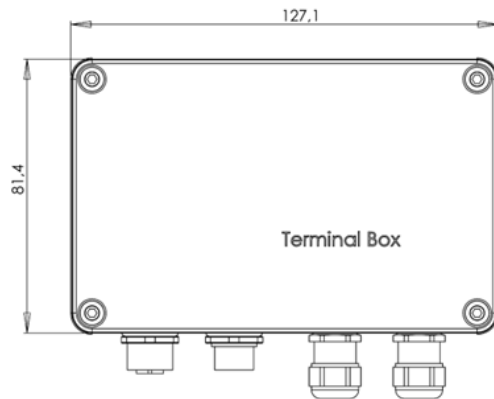



## WIO Integrated (WIOI) dimensions in mm

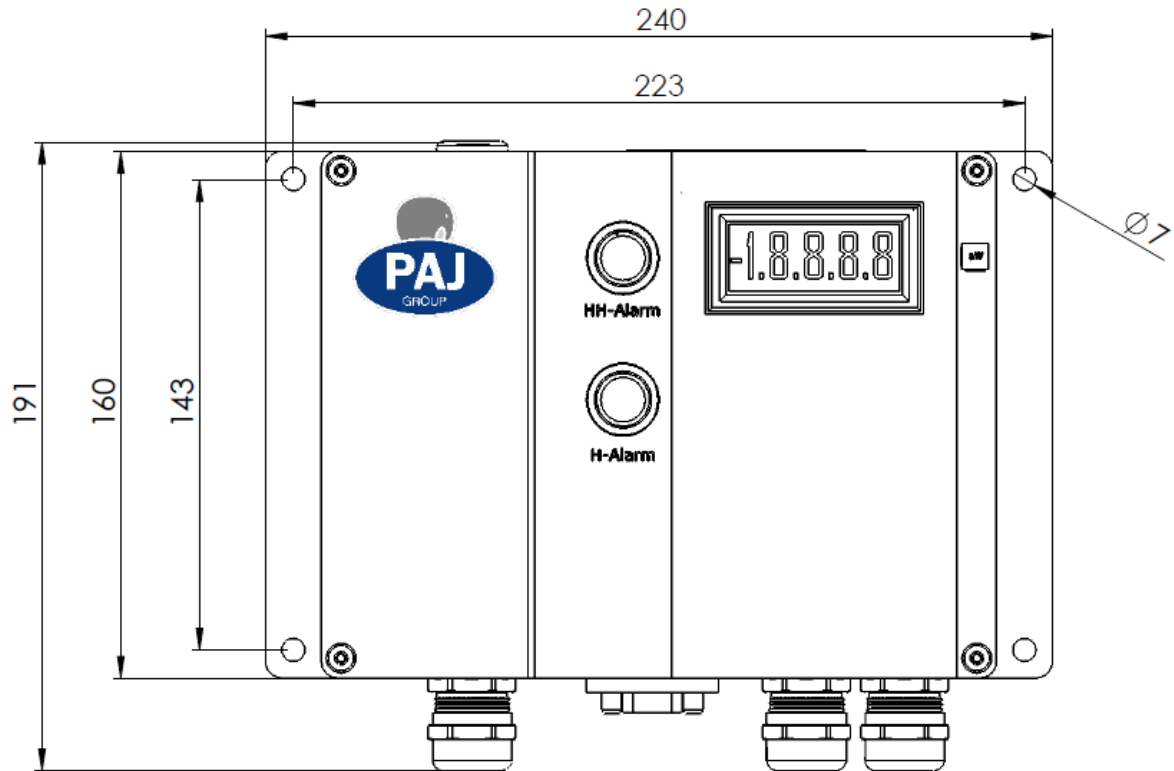

## WIOI Sensor, short pipe, 1/2" thread, dimensions in mm:

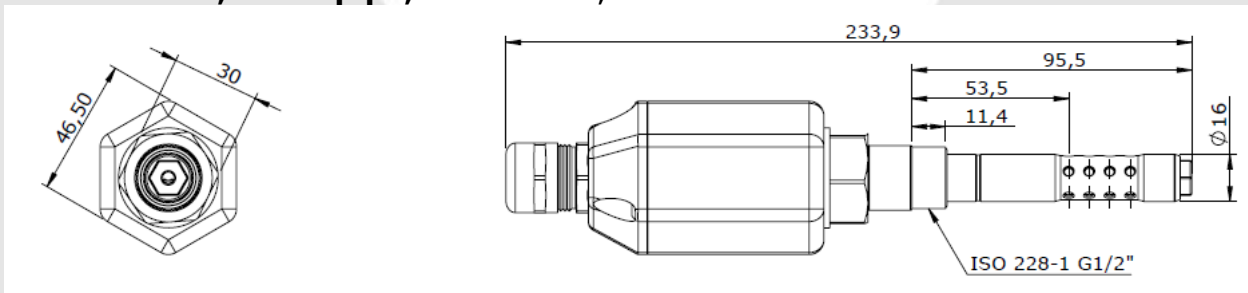

## WIOI Sensor, long pipe, 1/2" thread, dimensions in mm:

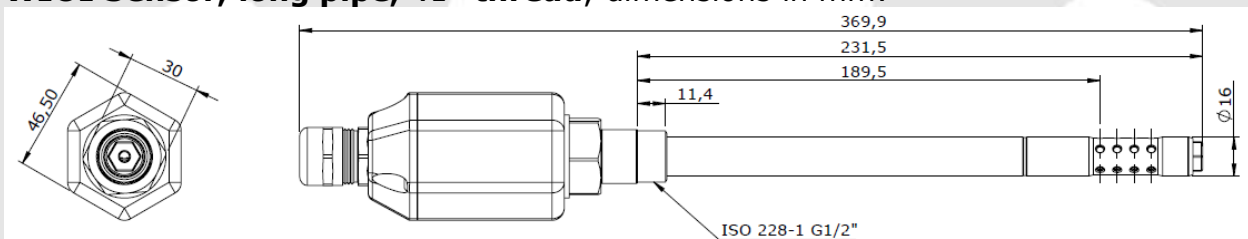



**WIOI Sensor, long pipe, 3/4" thread, dimensions in mm:**

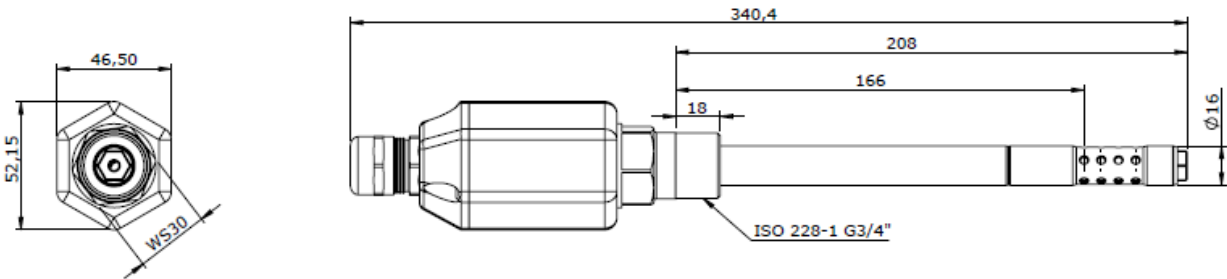



## Technical data, Sensors



WIO Standard 3/4" (ISO 228-1 G3/4"), Short



WIO Standard 1/2" (ISO 228-1 G1/2"), Short



WIO Ball Valve pipe, Long

<b>Output</b>	
Analogue output (galvanic isolated)	4 – 20 mA for $a_w$
Analogue output (galvanic isolated)	4 – 20 mA for temperature (0°C – 100°C)
Max. Load (analogue output)	< 500Ω
Measurement Range (4 – 20 mA)	0,01 – 1,00 $a_w$
Accuracy (0,05-0,95 $a_w$ )	± 0,03 $a_w$
Accuracy (outside 0,05-0,95 $a_w$ )	± 0,05 $a_w$
Resolution	< 0,004 $a_w$
Digital output	Communication RS232
Communication Protocol	Modbus RTU
<b>Input</b>	
Supply nominal voltage	24V DC ± 10%
Max. residual voltage ripple	10%
Maximum Load current	200 mA
Max. Power input	< 4,8 VA



<b>Relays</b>	
Contact arrangement	2 x Normally Closed (NC)
Rated voltage	60V
Rated current (40°C)	1A
Max. DC Load breaking capacity	
Relay 1	„High Alarm“
Relay 2	„High High Alarm“
Default High Alarm	0,50 a <sub>w</sub>
Default High High Alarm	0,90 a <sub>w</sub>

<b>Socket specification</b>	
Connector design	1x male socket, 1x female socket
Connector locking system	Screw-locking, M12x1
Wire gauge	0,25 mm <sup>2</sup>
Contacts	8 Pol
Rated voltage	60V
Rated current (40°C)	1A

<b>Cable specification</b>	
Cable design	Multipair overall screened cable
Outlet diameter	9,9 mm
Voltage class	0,6/1kV
Wires	4x2 twisted pair
Wire gauge	0,75 mm <sup>2</sup>

<b>Media for measurement</b>	
Lubrication oil	Grade SAE 30/TBN 5-10
Max. Oil temperature	100°C
Max. Oil pressure	Sensor mounting method in application: Ball valve mounted: Max. 10 Bar Thread mounted: Max. 20 Bar



<b>Response times</b>	
Delay before valid data from start-up	< 30 s
Delay before valid data from installation (first use)	10 minutes
<b>Device Failure Indication</b>	
Analogue output	< 2 mA
<b>Manual test</b>	
Press sensor test button for 5 seconds	High Alarm turns on for 5 seconds
Press sensor test button for 10 seconds	High Alarm turns off High High Alarm turns on for 5 seconds
Press sensor test button for 15 seconds	Normal operating and test button ignored
<b>Miscellaneous</b>	
Ambient Temperature, running / storage	0 - 90°C / -30 - +95°C
Relative humidity for running and storage	10% up to 95%, no condensation
Re calibration	Recommended with max 3 years interval
Warranty	2 years
<b>Approvals</b>	
Germanischer Loyd	WIO products are EU approval under 75 965 - 09 HH date 2009-11-30
<b>Enclosure</b>	
Weight for WIO standard	650 grams
Weight for WIO Ball valve pipe	790 grams
Connection (mechanical)	ISO 228-1 G ½" or ¾" thread 2 x 8-pole connectors, male and female, M12x1 thread
Enclosure material	Stainless Steel/Aluminum EN44100 (Former 4261)
Protective type	IP66



## Technical Data Terminal Box



<b>Output</b>	
Analogue output	See the specifications for sensor's analogue output
Digital output	See the specifications for sensor's digital output
<b>Input</b>	
Supply nominal voltage	24V DC $\pm$ 10%
Max. residual voltage ripple	10%
Maximum Load current	200 mA
Max. Power input	< 4,8 VA
<b>Relays</b>	
Contact arrangement	2 x Normally Open (NO)
Rated voltage	250 VAC
Max. switching voltage	400VAC
Rated current	2A
Breaking capacity max.	1250VA
<b>Enclosure</b>	
Weight	650 grams
Connection to sensor (mechanical)	2 x 8-pole connectors, male and female, M12x1 thread
Connection (mechanical)	2 x M20 gland, cable diameter 6 to 12 mm 1 x D-sub9, male
Enclosure material	Aluminum
Protective type	IP66
Warranty	2 years



## **FUNCTIONING**

---

Terminal box shall be provided with 24vdc.  
Terminal box supply 24vdc on to WIO sensor.  
WIO sensor delivers mA, digital values and relay status to the terminal box.





## Technical Data Terminal Display Box



<b>Output</b>	
Analogue output	See the specifications for sensor's analogue output
Digital output	See the specifications for sensor's digital output
<b>Input</b>	
Supply nominal voltage	24V DC $\pm$ 10%
Max. residual voltage ripple	10%
Maximum Load current	200 mA
Max. Power input	< 4,8 VA
<b>Relays</b>	
Contact arrangement	2 x Normally Open (NO)
Rated voltage	250 VAC
Max. switching voltage	400VAC
Rated current	2A
Breaking capacity max.	1250VA
<b>Display version - <math>a_w</math> (water activity from 0,01 to 1,00)</b>	
Accuracy (0,05-0,95 $a_w$ )	$\pm$ 0,03 $a_w$
Resolution	<0,004 $a_w$
<b>Display version - PPM (H<sub>2</sub>O)</b>	
Accuracy (0,05-0,95 $a_w$ )	$\pm$ 30%
Resolution	1 PPM
<b>Enclosure</b>	
Weight	650 grams
Connection to sensor (mechanical)	2 x 8-pole connectors, male and female, M12x1 thread
Connection (mechanical)	2 x M20 gland, cable diameter 6 to 12 mm 1 x D-sub9, male
Enclosure material	Aluminum
Protective type	IP66
Warranty	2 years

PAJ Sensor A/S • Grundtvigs Allé 163 • DK-6400 Sønderborg

Tel: +45 74 43 71 81 • Fax: +45 74 43 71 91 • CVR: 3459-1229 • www.paj-sensor.com • e-mail: paj@paj.dk

APPROVALS: ISO 9001, ISO 14001, ISO 13485, IEC 61340-51 & IPC-A-610 CLASS 3

03-01-0501-CRJ-04 Side 25 af 74



## FUNCTIONING

---

Terminal box shall be provided with 24vdc.  
Terminal box supply 24vdc on to WIO sensor.  
Terminal box measuring mA from the sensor, and convert it to  $a_w$  or PPM value.  
WIO sensor delivers mA, digital value and relay status to the terminal box.

## IMPORTANT

---

The display is an indication of the water level in the oil. Display can be shipped as PPM or  $a_w$ .

Upon ordering a PPM display the customer must specify the water saturation point in PPM of the used oil at the preferred working temperature of the oil. The saturation point is typically between 3000-10000 PPM. Alternatively the customer can ship 10 liters of oil to PAJ Sensor A/S for inspection including specification of the working oil temperature.

## WARNING

---

All displays will show from positive values when operating properly. There will appear a negative value during start-up, after 5 seconds the value will be in positive measurement range. Otherwise, if a negative value is present the Terminal box might have been installed incorrectly.



## NOTE

WIO300 uses 3 different units for the measurement of water in oil:

- 1)  **$a_w$** : WIO measures humidity in  **$a_w$** . The range is 0.01...1.00  $a_w$ .
- 2) **%RH** (relative humidity) is identical to the unit  $a_w$  multiplied by 100. The range is 1...100 %RH
- 3) **ppm**: WIO can convert  **$a_w$**  to **ppm**. In this case the saturation point, at a given temperature, must be known. Output in ppm is only reliable at this temperature.

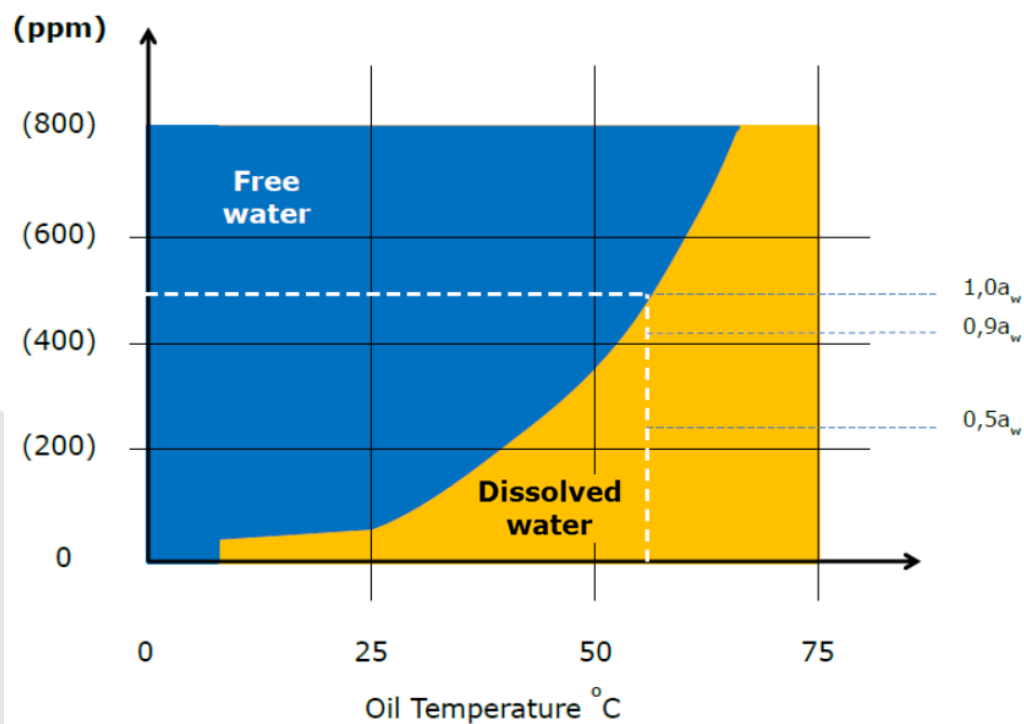



## Technical Data Terminal Box Alarm



<b>Output</b>	
Analogue output	See the specifications for sensor's analogue output
Digital output	See the specifications for sensor's digital output
<b>Input</b>	
Supply nominal voltage	24V DC $\pm$ 10%
Max. residual voltage ripple	10%
Maximum Load current	200 mA
Max. Power input	< 4,8 VA
<b>Relays</b>	
Contact arrangement	2 x Normally Open (NO)
Rated voltage	250 VAC
Max. switching voltage	400VAC
Rated current	2A
Breaking capacity max.	1250VA
<b>Buzzer</b>	
Oscillation frequency	3000 $\pm$ 500 Hz
Sound pressure level	85db by open housing
Tone	pulsed
<b>Button with LED</b>	
Blink frequency	2 Hz
Color	RED
<b>Enclosure</b>	
Weight	530 grams
Connection to sensor (mechanical)	2 x 8-pole connectors, male and female, M12x1 thread
Connection (mechanical)	2 x M20 gland, cable diameter 6 to 12 mm 1 x D-sub9, male
Enclosure material	Aluminum
Protective type	IP66
Warranty	2 years



## FUNCTIONING

---

Terminal box shall be provided with 24vdc.  
Terminal box supply 24vdc on to WIO sensor.  
Terminal box indicate the relay status from the WIO sensor.  
WIO sensor delivers mA, digital values and relay status to the terminal box.

H-Alarm LED is for indication of the High Alarm relay state from the WIO sensor. When the alarm condition is generated by the WIO sensor, then the High Alarm relay is open and the H-Alarm LED flash red ON/OFF sequence to show the High Alarm state, and the alarm signal buzzer will be switched ON.

HH-Alarm LED is for indication of the High High Alarm relay state from the WIO sensor. When the alarm condition is generated by the WIO sensor, then the High High Alarm relay is open and the HH-Alarm LED flash red ON/OFF sequence to show the High High Alarm state, and the alarm signal buzzer will be switched ON.

The H-Alarm LED or HH-Alarm LED will stay in blinking mode until the H-Alarm or HH-Alarm button is pressed, then the LED constantly turned on. The alarm signal buzzer will stay on until the H-Alarm or HH-Alarm button is pressed.



Abstract representation of the H-Alarm and HH-Alarm button and LED function:

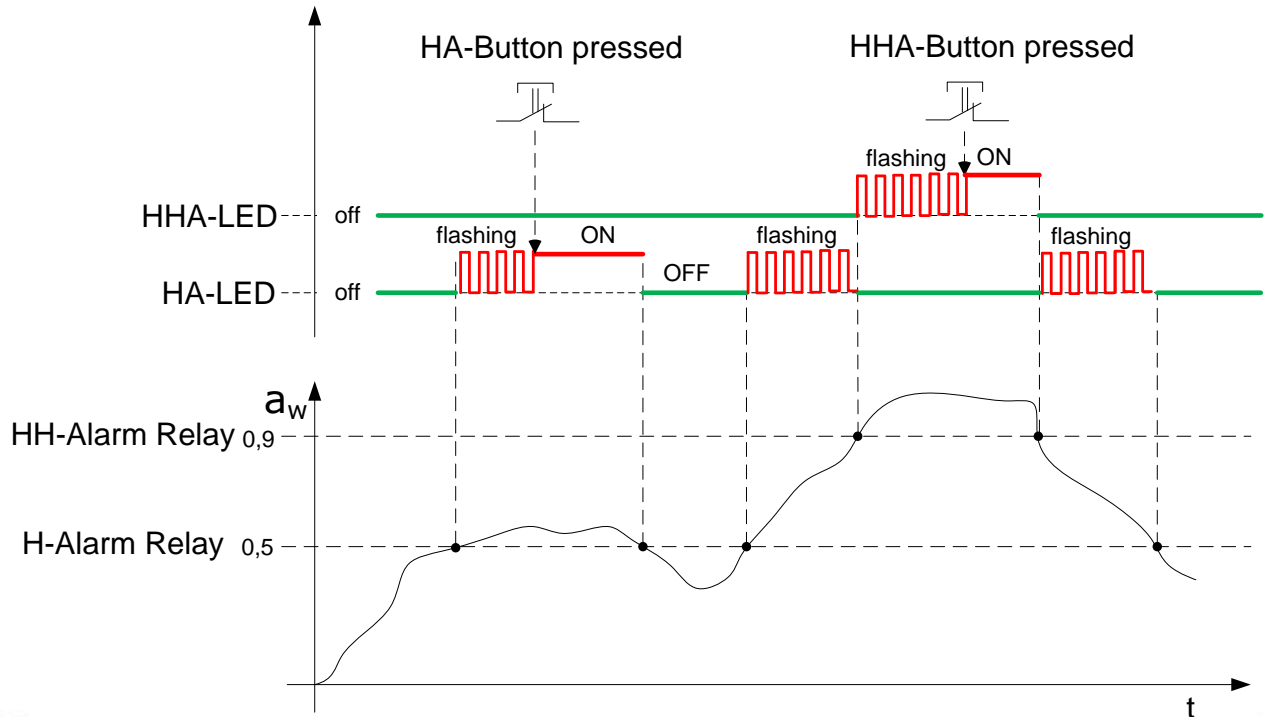

Figure 1: H-Alarm and HH-Alarm button function



## Technical Data Terminal Box Alarm Buzzer



<b>Output</b>	
Analogue output	See the specifications for sensor's analogue output
Digital output	See the specifications for sensor's digital output
<b>Input</b>	
Supply nominal voltage	24V DC $\pm$ 10%
Max. residual voltage ripple	10%
Maximum Load current	200 mA
Max. Power input	< 4,8 VA
<b>Relays</b>	
Contact arrangement	2 x Normally Open (NO)
Rated voltage	250 VAC
Max. switching voltage	400VAC
Rated current	2A
Breaking capacity max.	1250VA
<b>Display version - <math>a_w</math> (water activity from 0,01 to 1,00)</b>	
Accuracy (0,05-0,95 $a_w$ )	$\pm$ 0,03 $a_w$
Resolution	<0,004 $a_w$
<b>Display version - PPM (H<sub>2</sub>O)</b>	
Accuracy (0,05-0,95 $a_w$ )	$\pm$ 30%
Resolution	1 PPM
<b>Buzzer</b>	
Oscillation frequency	3000 $\pm$ 500 Hz
Sound pressure level	85db by open housing
Tone	pulsed



<b>Button with LED</b>	
Blink frequency	2 Hz
Color	RED
<b>Enclosure</b>	
Weight	650 grams
Connection to sensor (mechanical)	2 x 8-pole connectors, male and female, M12x1 thread
Connection (mechanical)	2 x M20 gland, cable diameter 6 to 12 mm 1 x D-sub9, male
Enclosure material	Aluminum
Protective type	IP66
Warranty	2 years

## FUNCTIONING

Terminal box shall be provided with 24vdc.  
Terminal box supply 24vdc on to WIO sensor.  
Terminal box measuring mA from the sensor, and convert it to  $a_w$  or PPM value.  
WIO sensor delivers mA, digital values and relay status to the terminal box.

H-Alarm LED is for indication of the High Alarm relay state from the WIO sensor. When the alarm condition is generated by the WIO sensor, then the High Alarm relay is open and the H-Alarm LED flash red ON/OFF sequence to show the High Alarm state, and the alarm signal buzzer will be switched ON.

HH-Alarm LED is for indication of the High High Alarm relay state from the WIO sensor. When the alarm condition is generated by the WIO sensor, then the High High Alarm relay is open and the HH-Alarm LED flash red ON/OFF sequence to show the High High Alarm state, and the alarm signal buzzer will be switched ON.

The H-Alarm LED or HH-Alarm LED will stay in blinking mode until the H-Alarm or HH-Alarm button is pressed, then the LED constantly turned on. The alarm signal buzzer will stay on until the H-Alarm or HH-Alarm button is pressed.





Abstract representation of the H-Alarm and HH-Alarm button and LED function:

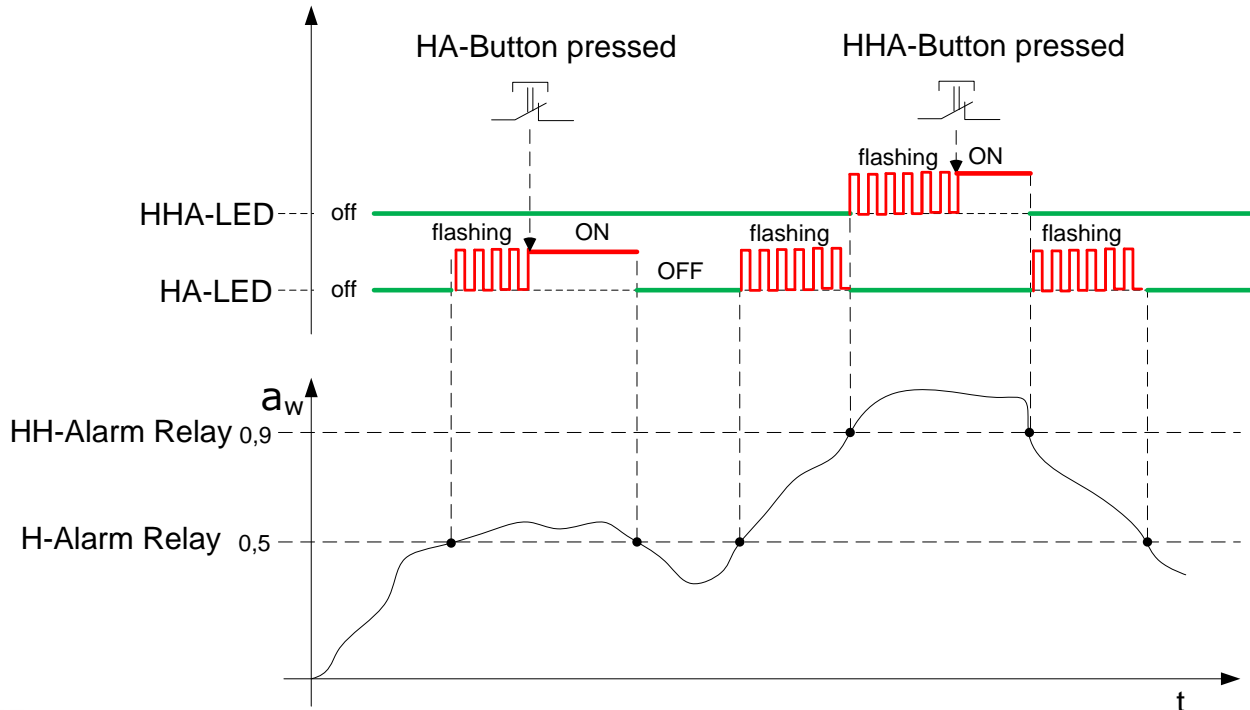

Figure 2: H-Alarm and HH-Alarm button function

## IMPORTANT

The display is an indication of the water level in the oil. Display can be shipped as PPM or  $a_w$ .

Upon ordering a PPM display the customer must specify the water saturation point in PPM of the used oil at the preferred working temperature of the oil. The saturation point is typically between 3000-10000 PPM. Alternatively the customer can ship 10 liters of oil to PAJ Sensor A/S for inspection including specification of the working oil temperature.

## WARNING

All displays will show from positive values when operating properly. There will appear a negative value during start-up, after 5 seconds the value will be in positive measurement range. Otherwise, if a negative value is present the Terminal box might have been installed incorrectly.



## NOTE

WIO300 uses 3 different units for the measurement of water in oil:

- 1)  **$a_w$** : WIO measures humidity in  **$a_w$** . The range is 0.01...1.00  $a_w$ .
- 2) **%RH** (relative humidity) is identical to the unit  $a_w$  multiplied by 100. The range is 1...100 %RH
- 3) **ppm**: WIO can convert  **$a_w$**  to **ppm**. In this case the saturation point, at a given temperature, must be known. Output in ppm is only reliable at this temperature.

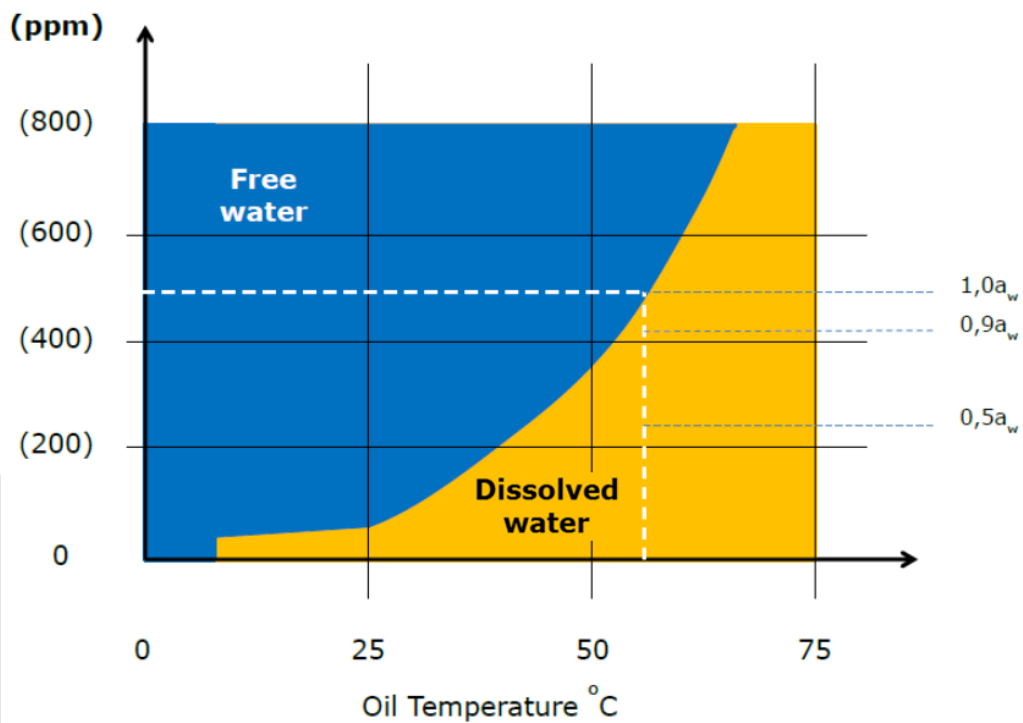



## Technical Data Terminal Box Alarm Buzzer



<b>Output</b>	
Analogue output	See the specifications for sensor's analogue output
Digital output	See the specifications for sensor's digital output
<b>Input</b>	
Supply nominal voltage	24V DC $\pm$ 10%
Max. residual voltage ripple	10%
Maximum Load current	200 mA
Max. Power input	< 4,8 VA
<b>Relays</b>	
Contact arrangement	2 x Normally Open (NO)
Rated voltage	250 VAC
Max. switching voltage	400VAC
Rated current	2A
Breaking capacity max.	1250VA
<b>Display version - a<sub>w</sub> (water activity from 0,01 to 1,00)</b>	
Accuracy (0,05-0,95 a <sub>w</sub> )	$\pm$ 0,03 a <sub>w</sub>
Resolution	<0,004 a <sub>w</sub>
<b>Display version - PPM (H<sub>2</sub>O)</b>	
Accuracy (0,05-0,95 a <sub>w</sub> )	$\pm$ 30%
Resolution	1 PPM
<b>Display version - °C</b>	
Accuracy	$\pm$ 2°C
Resolution	0,01 °C



<b>Buzzer</b>	
Oscillation frequency	3000±500 Hz
Sound pressure level	85db by open housing
Tone	pulsed
<b>Button with LED</b>	
Blink frequency	2 Hz
Color	RED
<b>Enclosure</b>	
Weight	750 grams
Connection to sensor (mechanical)	2 x 8-pole connectors, male and female, M12x1 thread
Connection (mechanical)	2 x M20 gland, cable diameter 6 to 12 mm 1 x D-sub9, male
Enclosure material	Aluminum
Protective type	IP66
Warranty	2 years



## FUNCTIONING

---

Terminal box shall be provided with 24vdc.  
Terminal box supply 24vdc on to WIO sensor.  
Terminal box measuring mA from the sensor, and convert it to  $a_w$  or PPM value.  
WIO sensor delivers mA, digital values and relay status to the terminal box.

H-Alarm LED is for indication of the High Alarm relay state from the WIO sensor. When the alarm condition is generated by the WIO sensor, then the High Alarm relay is open and the H-Alarm LED flash red ON/OFF sequence to show the High Alarm state, and the alarm signal buzzer will be switched ON.

HH-Alarm LED is for indication of the High High Alarm relay state from the WIO sensor. When the alarm condition is generated by the WIO sensor, then the High High Alarm relay is open and the HH-Alarm LED flash red ON/OFF sequence to show the High High Alarm state, and the alarm signal buzzer will be switched ON.

The H-Alarm LED or HH-Alarm LED will stay in blinking mode until the H-Alarm or HH-Alarm button is pressed, then the LED constantly turned on. The alarm signal buzzer will stay on until the H-Alarm or HH-Alarm button is pressed.



Abstract representation of the H-Alarm and HH-Alarm button and LED function:

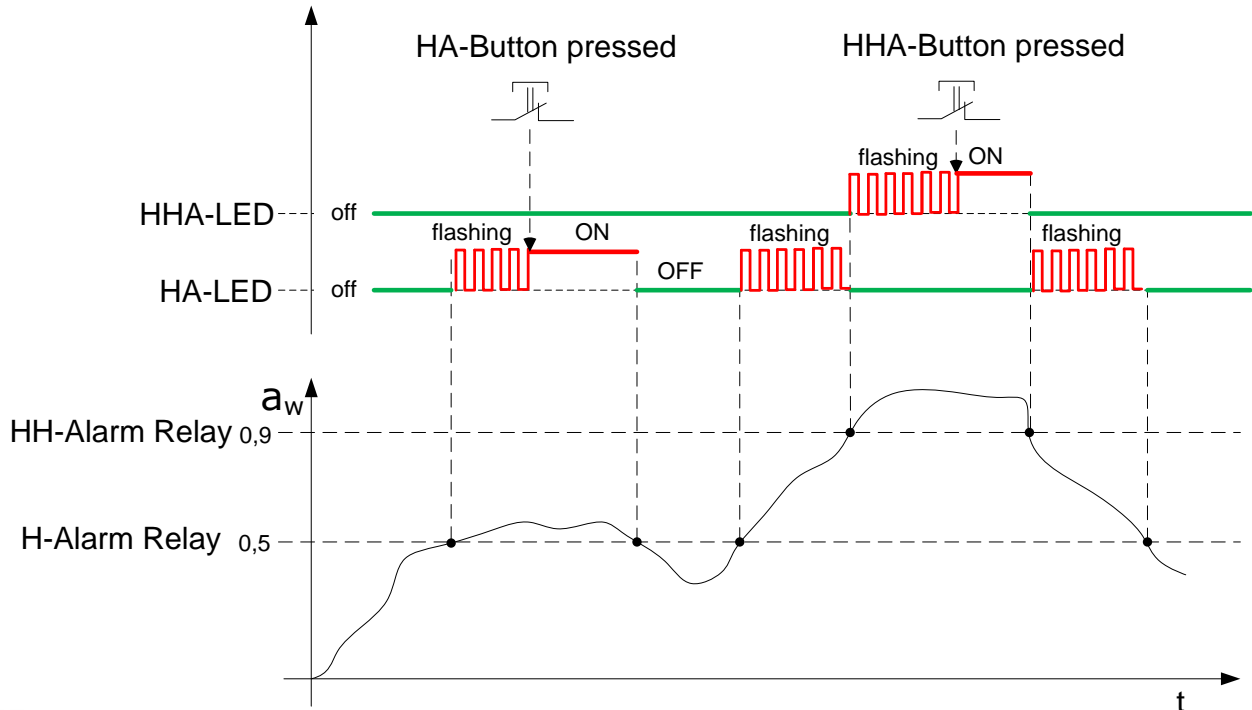

Figure 2: H-Alarm and HH-Alarm button function

## IMPORTANT

The display is an indication of the water level in the oil. Display can be shipped as PPM or  $a_w$ .

Upon ordering a PPM display the customer must specify the water saturation point in PPM of the used oil at the preferred working temperature of the oil. The saturation point is typically between 3000-10000 PPM. Alternatively the customer can ship 10 liters of oil to PAJ Sensor A/S for inspection including specification of the working oil temperature.

## WARNING

All displays will show from positive values when operating properly. There will appear a negative value during start-up, after 5 seconds the value will be in positive measurement range. Otherwise, if a negative value is present the Terminal box might have been installed incorrectly.



**NOTE**

WIO300 uses 3 different units for the measurement of water in oil:

- 1)  **$a_w$** : WIO measures humidity in  **$a_w$** . The range is 0.01...1.00  $a_w$ .
- 2) **%RH** (relative humidity) is identical to the unit  $a_w$  multiplied by 100. The range is 1...100 %RH
- 3) **ppm**: WIO can convert  **$a_w$**  to **ppm**. In this case the saturation point, at a given temperature, must be known. Output in ppm is only reliable at this temperature.

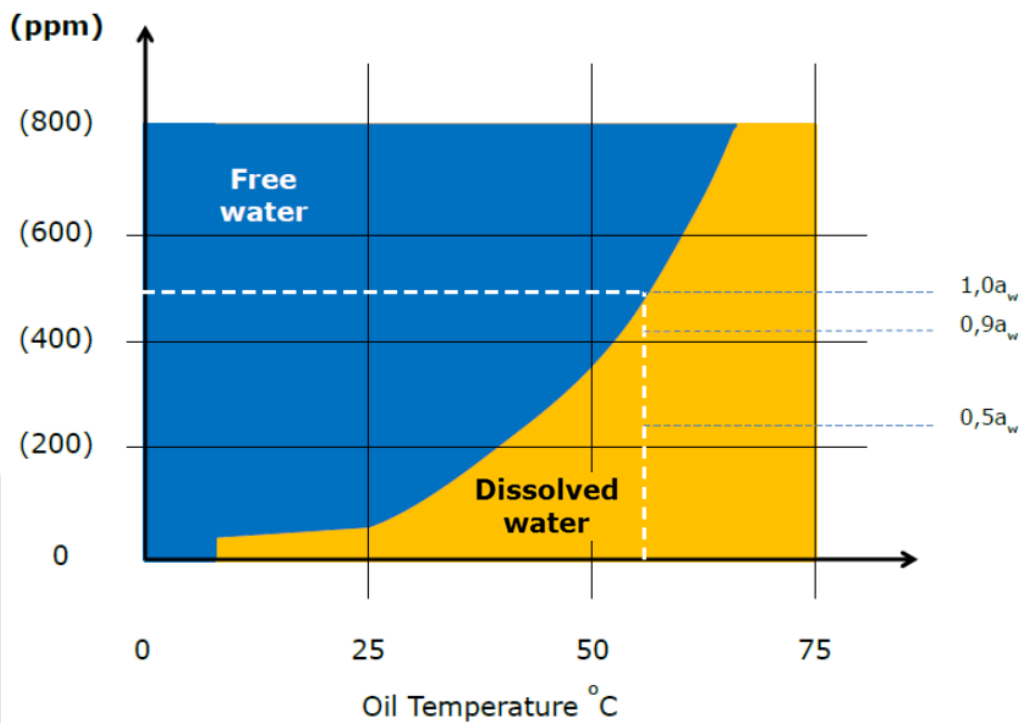



## Technical data, WIOI (WIO Integrated)



<b>Output</b>	
Analogue output (galvanic isolated)	4 – 20 mA for $a_w$
Max. Load (analogue output)	< 500 $\Omega$
Measurement Range (4 – 20 mA)	0,01 – 1,00 $a_w$
Accuracy (0,05-0,95 $a_w$ )	$\pm 0,03 a_w$
Accuracy (outside 0,05-0,95 $a_w$ )	$\pm 0,05 a_w$
Resolution	< 0,004 $a_w$
Digital output	Communication RS232
Communication Protocol	Modbus RTU
<b>Input</b>	
Supply nominal voltage	24V DC $\pm 10\%$
Max. residual voltage ripple	10%
Maximum Load current	200 mA
Max. Power input	< 4,8VA





<b>Relays</b>	
Contact arrangement	2 x Normally Open (NO)
Rated voltage	250VAC
Max. switching voltage	400VAC
Rated current	2A
Breaking capacity max.	1250VA
Max. DC Load breaking capacity	
Relay 1	„High Alarm“
Relay 2	„High High Alarm“
Default High Alarm	0,50 a <sub>w</sub>
Default High High Alarm	0,90 a <sub>w</sub>

<b>Cable specification</b>	
Cable design	Multipair overall screened cable
Outlet diameter	9,9 mm
Voltage class	0,6/1kV
Wires	4x2 twisted pair
Wire gauge	0,75 mm <sup>2</sup>

<b>Media for measurement</b>	
Lubrication oil	Grade SAE 30/TBN 5-10
Max. Oil temperature	100°C
Max. Oil pressure	Sensor mounting method in application: Ball valve mounted: Max. 10 Bar Thread mounted: Max. 20 Bar

<b>Response times</b>	
Delay before valid data from start-up	< 30 s
Delay before valid data from installation (first use)	10 minutes



<b>Device Failure Indication</b>	
Analogue output	< 2 mA
<b>Manual test</b>	
Press sensor test-button for 5 seconds	High Alarm turns on for 5 seconds
Press sensor test-button for 10 seconds	High Alarm turns off High High Alarm turns on for 5 seconds
Press sensor test-button for 15 seconds	Normal operating and test button ignored
<b>Display version - a<sub>w</sub> (water activity from 0,01 to 1,00)</b>	
Accuracy (0,05-0,95 a <sub>w</sub> )	± 0,03 a <sub>w</sub>
Resolution	<0,004 a <sub>w</sub>
<b>Display version - PPM (H<sub>2</sub>O)</b>	
Accuracy (0,05-0,95 a <sub>w</sub> )	±30%
Resolution	1 PPM
<b>Buzzer</b>	
Oscillation frequency	3000±500 Hz
Sound pressure level	85db by open housing
Tone	pulsed
<b>Button with LED</b>	
Blink frequency	2 Hz
Color	RED
<b>Enclosure</b>	
Weight	4000 grams
Connection (mechanical)	ISO 228-1 G ½" or ¾" thread 2 x gland M20, cable diameter 6 to 12 mm 1 x D-sub9, male
Enclosure material	Stainless Steel/Aluminum EN44100 (Former 4261)
Protective type	IP66



<b>Miscellaneous</b>	
Ambient Temperature, running / storage	0 - 90°C / -30 - +95°C
Relative humidity for running and storage	10% up to 95%, no condensation
Re calibration	Recommended with max 3 years interval
Warranty	2 years
<b>Approvals</b>	
Germanischer Lloyd	WIO products are EU approval under 75 965 – 09 HH date 2009-11-30

## **FUNCTIONING**

---

Terminal box shall be provided with 24vdc.  
Terminal box supply 24vdc on to WIO sensor.  
Terminal box measuring mA from the sensor, and convert it to  $a_w$  or PPM value.  
WIO sensor delivers mA, digital values and relay status to the terminal box.

H-Alarm LED is for indication of the High Alarm relay state from the WIO sensor. When the alarm condition is generated by the WIO sensor, then the High Alarm relay is open and the H-Alarm LED flash red ON/OFF sequence to show the High Alarm state, and the alarm signal buzzer will be switched ON.

HH-Alarm LED is for indication of the High High Alarm relay state from the WIO sensor. When the alarm condition is generated by the WIO sensor, then the High High Alarm relay is open and the HH-Alarm LED flash red ON/OFF sequence to show the High High Alarm state, and the alarm signal buzzer will be switched ON.

The H-Alarm LED or HH-Alarm LED will stay in blinking mode until the H-Alarm or HH-Alarm button is pressed, then the LED constantly turned on. The alarm signal buzzer will stay on until the H-Alarm or HH-Alarm button is pressed.



Abstract representation of the H-Alarm and HH-Alarm button and LED function:

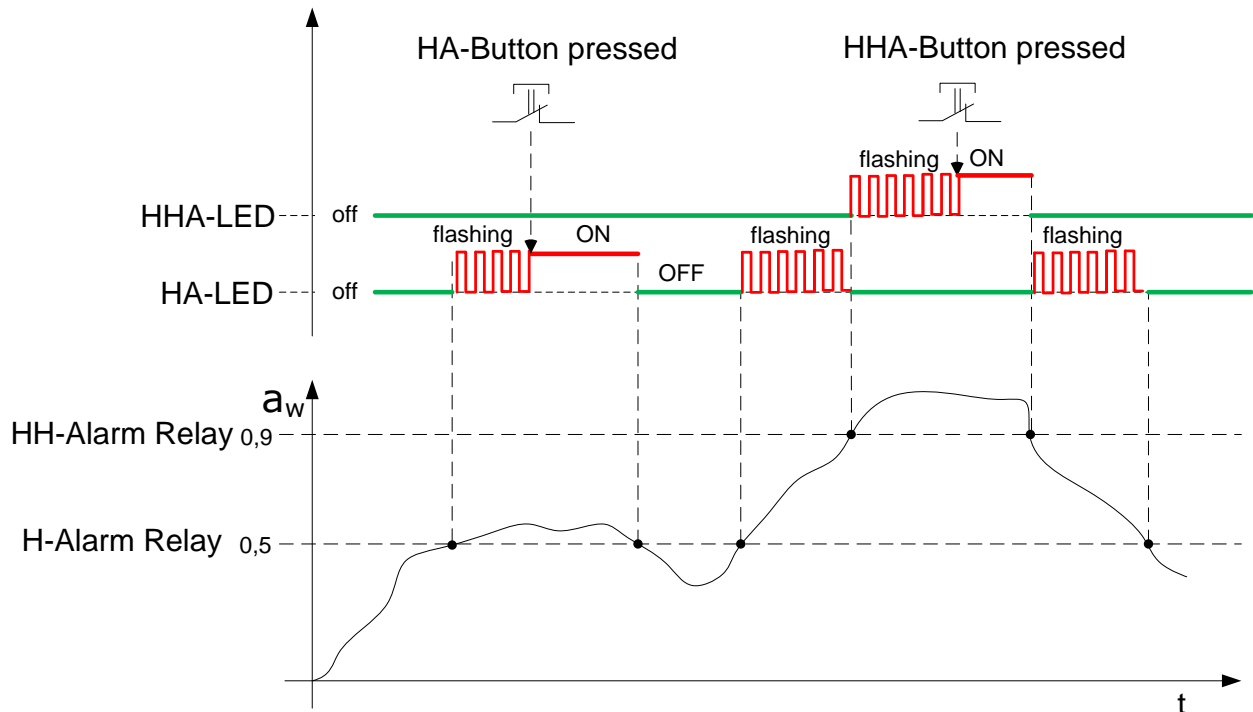

Figure 2: H-Alarm and HH-Alarm button function

## IMPORTANT

The display is an indication of the water level in the oil. Display can be shipped as PPM or  $a_w$ .

Upon ordering a PPM display the customer must specify the water saturation point in PPM of the used oil at the preferred working temperature of the oil. The saturation point is typically between 3000-10000 PPM. Alternatively the customer can ship 10 liters of oil to PAJ Sensor A/S for inspection including specification of the working oil temperature.

## WARNING

All displays will show from positive values when operating properly. There will appear a negative value during start-up, after 5 seconds the value will be in positive measurement range. Otherwise, if a negative value is present the Terminal box might have been installed incorrectly.



## NOTE

WIO300 uses 3 different units for the measurement of water in oil:

- 1)  **$a_w$** : WIO measures humidity in  **$a_w$** . The range is 0.01...1.00  $a_w$ .
- 2) **%RH** (relative humidity) is identical to the unit  $a_w$  multiplied by 100. The range is 1...100 %RH
- 3) **ppm**: WIO can convert  **$a_w$**  to **ppm**. In this case the saturation point, at a given temperature, must be known. Output in ppm is only reliable at this temperature.

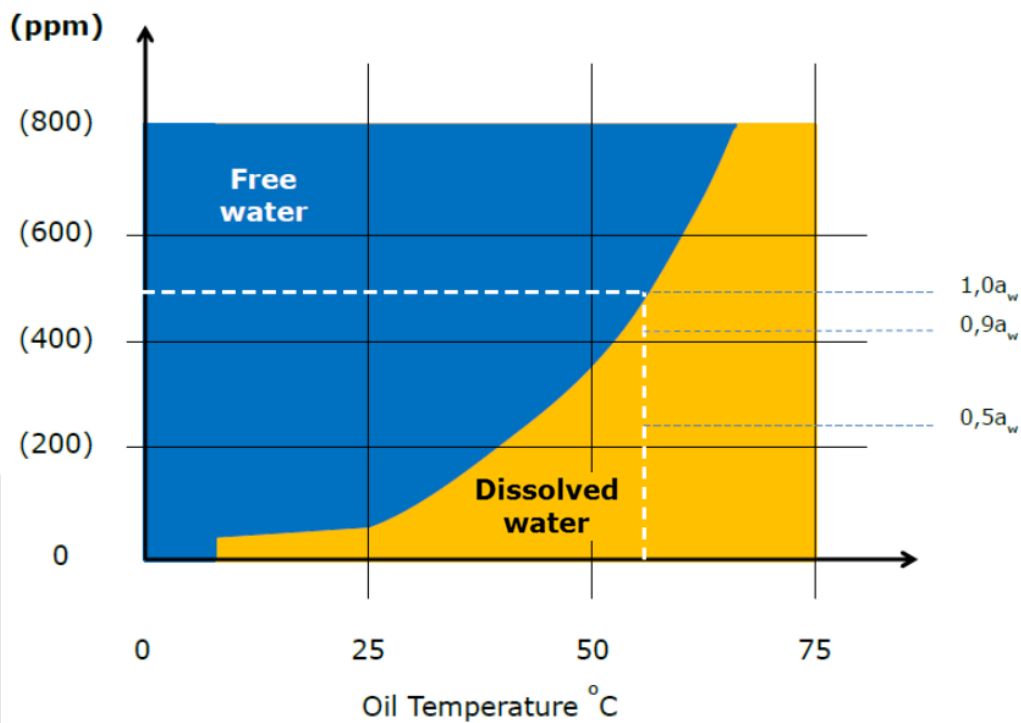



## Communication protocol for Modbus on RS232

PAJ Sensor have used the MODBUS application protocol V1.1b3, which can be downloaded from <http://modbus.org>.

Command list all value are HEX value

Item	Function code	Register Address	descriptions
Read relay status of HA	01	26	Value = 00 means there is a alarm
Read relay status of HHA	01	27	Value = 01 means no alarm
Read factory reset bit status	01	2A	Value = 01 then is WIO ready for factory reset
Read WIO S/N	03	04	Register 04 value = 52 10
	03	05	Register 05 value = 01 23
			S/N on the connected WIO = 52100123
Read HA alarm level	03	1E	Register 1E value = CD CC
	03	1F	Register 1F value = 4C 3F
			HA alarm level = CD CC 4C 3F => 0,80aW ( page 34)
Read HHA alarm level	03	20	Register 20 value = 66 66
	03	21	Register 21 value = 66 3F
			HHA alarm level = 66 66 66 3F => 0,90aW (page 34)
Read WIO type	03	23	Value = 03 then is a WIO300 connected
Read PPM max value	03	2D	Value =2D 21 changed to decimal 8500
Read WIO software version	03	2F	Value = 0115 then WIO software 1.15 are installed
Read calibration date	03	31	Register 31 value = 16 01
	03	32	Register 32 value = 20 14
			Then is WIO calibrated 16.01.2014
Read °C	04	06	Value = 07 6F changed to decimal = 1903
			Gives a temperature of 19,03°C in the Oil.
Read aW	04	07	Value = 11E3 changed to decimal = 4579
			Gives a moisture of 0,4579 aW in the Oil
Read mA output for aW	04	2C	Value = 04 6C changed to decimal = 1132 gives 11,32mA
Read mA output for °C	04	2E	Value = 02 C0 changed to decimal = 0704 gives 7,04mA
Read current PPM value	04	34	Value = 0F 34 changed to decimal = 3892 gives 3892 PPM
Read °F	04	35	Value = 19 E1 changed to decimal = 6625
			Gives a temperature of 66,25°F in the Oil
Set factory reset bit	05	2A	Make the WIO ready for factory reset
Complete factory reset	06	08	Before complete factory reset, must factory reset bit = 1
Change Modbus ID on WIO	06	24	Change the ID nr ( from factory is ID = 01 )
Change HA alarm level	10	1E	Write 01 10 00 1E 00 02 04 00 00 00 3F 33 3F
		1F	This will set HA level to 0,50aW (1E= 00 00 and 1F = 00 3F)
Change HHA alarm level	10	20	Write 01 10 00 20 00 02 04 66 66 66 3F E6 08
		21	This will set HHA level to 0,90aW (20= 66 66 and 21= 66 3F)
Change Modbus ID on WIO	00	24	If you use this function, there must only be 1 WIO connected, otherwise, all connected WIO units will get same ID number.

### Com Port setting

Baudrate	9600
Data bits	8
Parity	0 (none)
Stop bits	1



## Communication examples for function code 01

Read factory reset bit status

Request from user		Response from WIO	
Modbus ID	01	Modbus ID	01
Function code	01	Function code	01
Starting address Hi	00	Byte count	01
Starting address Lo (factory reset bit status)	2A	Output status	00
Quantity of outputs Hi	00	CRC	51
Quantity of outputs Lo	01	CRC	88
CRC Hi	DC		
CRC Lo	02		

## Communication examples for function code 03

Read WIO type

Request from user		Response from WIO300	
Modbus ID	01	Modbus ID	01
Function code	03	Function code	03
Starting address Hi	00	Byte count	02
Starting address Lo (WIO type)	23	Output status Hi	00
Quantity of outputs Hi	00	Output status Lo	03
Quantity of outputs Lo	01	CRC	F8
CRC Hi	75	CRC	45
CRC Lo	C0		

## Communication examples for function code 04

Read measured temperature

Request from user		Response from WIO (22,25°C)	
Modbus ID	01	Modbus ID	01
Function code	04	Function code	04
Starting address Hi	00	Byte count	02
Starting address Lo (Read °C)	06	Output status Hi	08
Quantity of outputs Hi	00	Output status Lo	B1
Quantity of outputs Lo	01	CRC	7E
CRC Hi	D1	CRC	84
CRC Lo	CB		

08B1 is a HEX value, rewritten for decimal numbers is 2225, it must be divided by 100 and the result is 22,25°C



## Communication examples for function code 05

Set factory reset bit

Request from user		Response from WIO	
Modbus ID	01	Modbus ID	01
Function code	05	Function code	05
Starting address Hi	00	Starting address Hi	00
Starting address Lo (factory reset bit status)	2A	Starting address Lo	2A
Register Value Hi	FF	Output status Hi	FF
Register Value Lo	00	Output status Lo	00
CRC Hi	AC	CRC	AC
CRC Lo	76	CRC	76

## Communication examples for function code 06

Complete the factory reset

Request from user		Response from WIO	
Modbus ID	01	Modbus ID	01
Function code	06	Function code	06
Starting address Hi	00	Starting address Hi	00
Starting address Lo (factory reset complete)	08	Starting address Lo	08
Quantity of outputs Hi	00	Output status Hi	00
Quantity of outputs Lo	01	Output status Lo	01
CRC Hi	C9	CRC	C9
CRC Lo	C8	CRC	C8

Before complete factory reset, the factory reset bit must be set to 01

## Communication examples for function code 10

Change HA alarm level to 0,55 aW

Request from user		Response from WIO	
Modbus ID	01	Modbus ID	01
Function code	10	Function code	10
Starting address Hi	00	Starting address Hi	00
Starting address Lo (HA alarm level)	1E	Starting address Lo	1E
Quantity of outputs Hi	00	Output status Hi	00
Quantity of outputs Lo	02	Output status Lo	02
Byte count	04	CRC	21
Register Value Hi	CD	CRC	CE
Register Value Lo	CC		
Register Value Hi	0C		
Register Value Lo	3F		
CRC Hi	C8		
CRC Lo	AC		





## CRC Calculation

Use google, search for: on-line Modbus CRC calculation.

Put in the calculator (only HEX value) 0101002A0001.

The calculator can give you 2 result 02DC or DC02.

If the result is 02DC, then just put 02 behind DC, and the CRC result will be DC02.

If the result is DC02. Then you have the CRC value

## Error codes

If you get a response back by a factor of 80 higher, as in the example shown, it is 3. digit explanation of the error code.

Example 1.

Request from user to WIO: 01 01 00 25 00 01 EC 01

Response from WIO: 01 81 02 C1 91

81 says that there is an error in the transmitted function code 01 message.

02 says that it is the wrong address.

Example 2.

Request from user to WIO: 01 10 00 1D 00 02 04 00 00 10 3F 7E EA

Response from WIO: 01 90 02 CD C1

90 says that there is an error in the transmitted function code 10 message.

02 says that it is the wrong address.

Example 3.

Request from user to WIO: 01 05 00 28 00 FF 0D 82

Response from WIO: 01 85 03 02 91

85 says that there is an error in the transmitted function code 05 message.

03 says that it is the wrong data for this address.

There are 4 possible error digit.

01 function code not supported

02 wrong address

03 too many output registers are selected or wrong input of data

04 error in reading the selected register



## Table for aW to HEX value

aW value	HEX value	aW value	HEX value
0, 10	CD CC CC 3D	0, 15	9A 99 19 3E
0, 20	CD CC 4C 3E	0, 25	00 00 80 3E
0, 30	98 99 99 3E	0, 35	33 33 B3 3E
0, 40	CD CC CC 3E	0, 45	66 66 E6 3E
0, 50	00 00 00 3F	0, 55	CD CC 0C 3F
0, 60	9A 99 19 3F	0, 65	66 66 26 3F
0, 70	33 33 33 3F	0, 75	00 00 40 3F
0, 80	CD CC 4C 3F	0, 85	9A 99 59 3F
0, 90	66 66 66 3F	0, 95	33 33 73 3F

## WIO-Software

Connect the USB-Stick to the PC and wait for windows has installed driver for this USB-Stick on PC. Then select Setup and wait until everything is installed. After install is completed, restart the PC and start WIO-Software, WIO-Software will even find the current communication port.



## EC-Declaration of Conformity

<b>PAJ Group, Grundtvigs Allé 163, DK-6400 Sønderborg, Denmark</b> Manufactory	
Declare under our sole responsibility that the product:	
unit identification: <b>WIO200 – WIO300 – WIO400 – WIO500</b>	product classification: <b>Water In Oil measuring instrument</b>
is a safety tested component according to EC Guideline: 2004/108/EC Electromagnetic compatibility 2006/95/EC Low voltage directive	
to which this declaration relates is in conformity with the following standard(s) or other normative documents(s): IEC 61326-1:2006-11-03, EN 61010-1:2001, EN 60529 Edition 2.1 2001-02, IEC 60068-1:1988, IEC 60068-2-2:2007, IEC 60068-2-1:2007, IEC 60068-2-30:2005, IEC 60068-2-6:2007, IEC 61000-4-16:1998-01, IEC 61000-4-6:2007, IEC 61000-4-3:2006, IEC 61000-4-5:2005, IEC 61000-4-2:2001, IEC 61000-4-4:2004	
The described product corresponds to the following European Directives: 2004/108/EC Electromagnetic compatibility 2006/95/EC Low voltage directive	
Consistency of a production sample device with the marked product in accordance with the Directives No: 2004/108/EC Electromagnetic compatibility 2006/95/EC Low voltage directive	
Notified agency/Address:	Germanischer Lloyd AG Head Office Deputy Head of Department Automation, Navigation and Communication (MC-EA) Vorsetzen 35 D-20459 Hamburg/Germany
75 956 – 09 HH Certification number	2009-11-30 Date of issue
The marked product is consistent with the examined production sample device.	
Technical documentation:	
Poul Jessen	
Grundtvigs Allé 163 • DK-6400 Sønderborg • Tel: +45 74 43 71 81 • E-Mail: paj@paj.dk	
Sønderborg, 15.04.2011 Date of issue	Poul Jessen, Managing Director Name and signature



# Type Approval Certificate

Germanischer Lloyd

This is to certify that the undernoted product(s) has/have been tested in accordance with the relevant requirements of the GL Type Approval System.

Certificate No. **7595609 HH**

Company **PAJ Systemteknik  
Grundtvigs Allé 163  
6400 Sønderborg, DENMARK**

Product Description **Water in Oil Monitor**

Type **WIO200**

Environmental Category **D, EMC 2**

Technical Data /  
Range of Application **Sensor which measures water content in lubrication oils on ship engine  
Condition Monitoring Component (according to GL I-1-17, Section 2, D.2.)  
  
WIO Sensor system nr: A01-110-0100-00  
Consists of:  
- WIO Sensor nr: A01-110-0101-00  
- Terminal Box nr: A01-110-0102-00  
- Sensor cables 2 pcs. Order nr: A01-110-0103-00  
  
The technical specification is shown on page 2.  
  
Software Version 111197-810 Rev 1.00**

Test Standard **Guidelines for the Performance of Type Approvals Chapter 2, Edition 2003**

Documents **Test report : 2009-02260 EMC, 2009-01456, 2009-01456R2LM, 2009-02373  
111197-900 WIO Sensor Specifications Rev.1.00, Datasheet 111197-902 Rev.1.00  
Software Questionnaire according to requirement class 3, dated 28.09.2009**

Remarks **Rules GL I-1-17 to be observed for Condition Monitoring (CM). Alarm settings have to be specified by engine manufacturer if sensor is used for CM.**

Valid until **2014-11-29**

Page **1 of 2**

Type Approval Symbol



File No. **I.A.10**

**Hamburg, 2009-11-30**

**Germanischer Lloyd**

Jürgen Wittburg

Marco Rinkel

This certificate is issued on the basis of "Regulations for the Performance of Type Tests, Part 0, Procedure".

Internet Publication: GL-Approvals



# Type Approval Certificate

Germanischer Lloyd

This is to certify that the undernoted product(s) has/have been tested in accordance with the relevant requirements of the GL Type Approval System.

Certificate No. **7595609 HH**

## Technical Specification:

Measuring range: 0,01 to 1,00 aw water content.  
Accuracy:  $\pm 0,03$  aw for the range 0...1 aw water content  
Resolution: Minimum 0,01 aw water content.  
Analogue output: 4 to 20 mA (galvanic isolated) 0,01 to 1 aw water content linear  
Max. Load (analogue outp.) < 500Ohm  
Alarm indications. Alarm indication via 2 x Alarm relays (NC).  
Media for measurement: Lubrication oil: Grade SAE 30/TBN 5-10  
Service temperature of media: 10 to 60 °C.  
Pressure range: 0 to 10 bar

Valid until **2014-11-29**

Page **2 of 2**

File No. **I.A.10**

**Hamburg, 2009-11-30**

Type Approval Symbol



**Germanischer Lloyd**

Jürgen Wittburg

Marco Rinkel

This certificate is issued on the basis of "Regulations for the Performance of Type Tests, Part 0, Procedure".

Internet Publication: GL-Approvals



# Appendix A1: Install 1 Terminal Box with 1 display

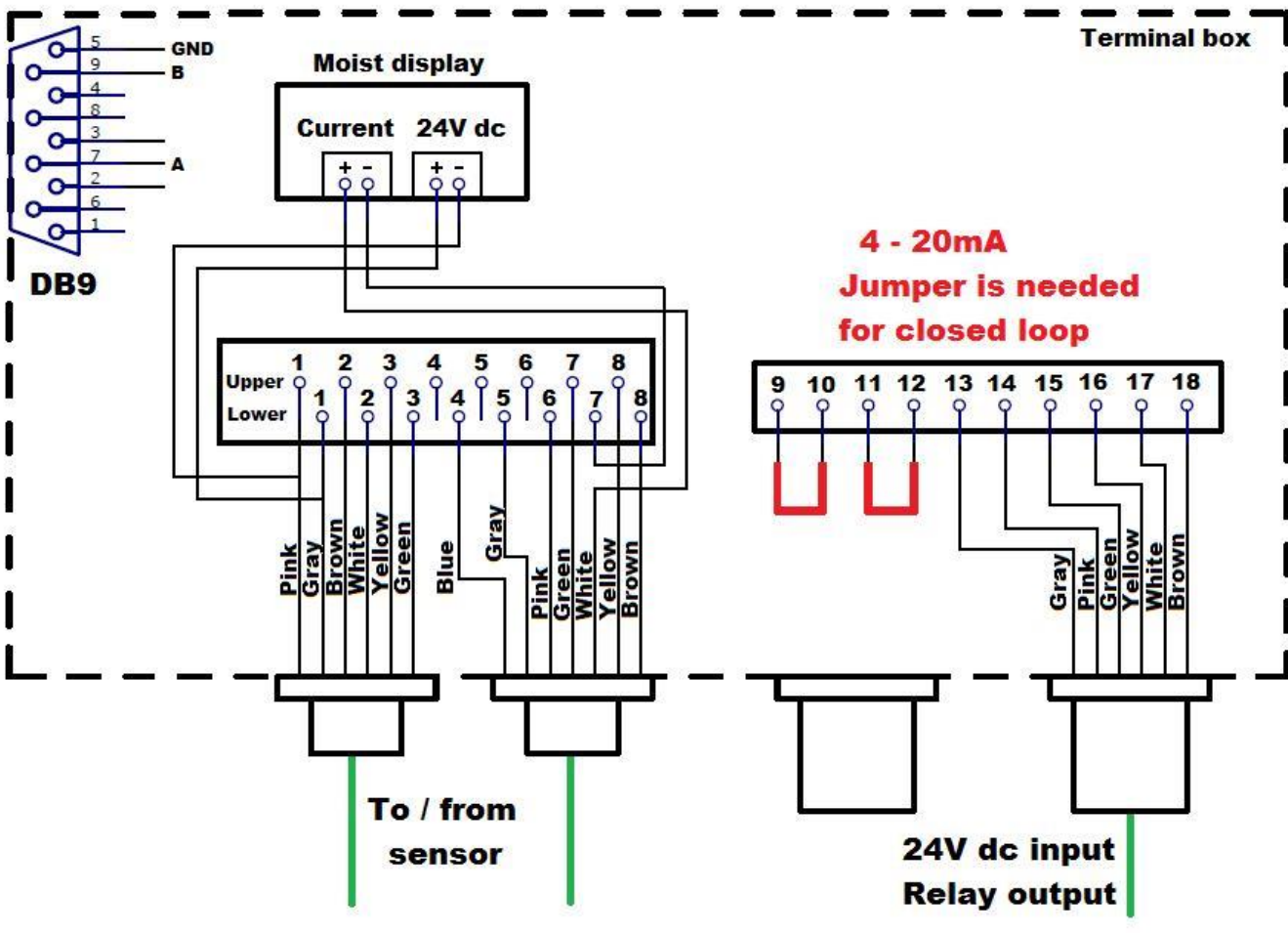



## Appendix A2: Install 1 Terminal Box with no display

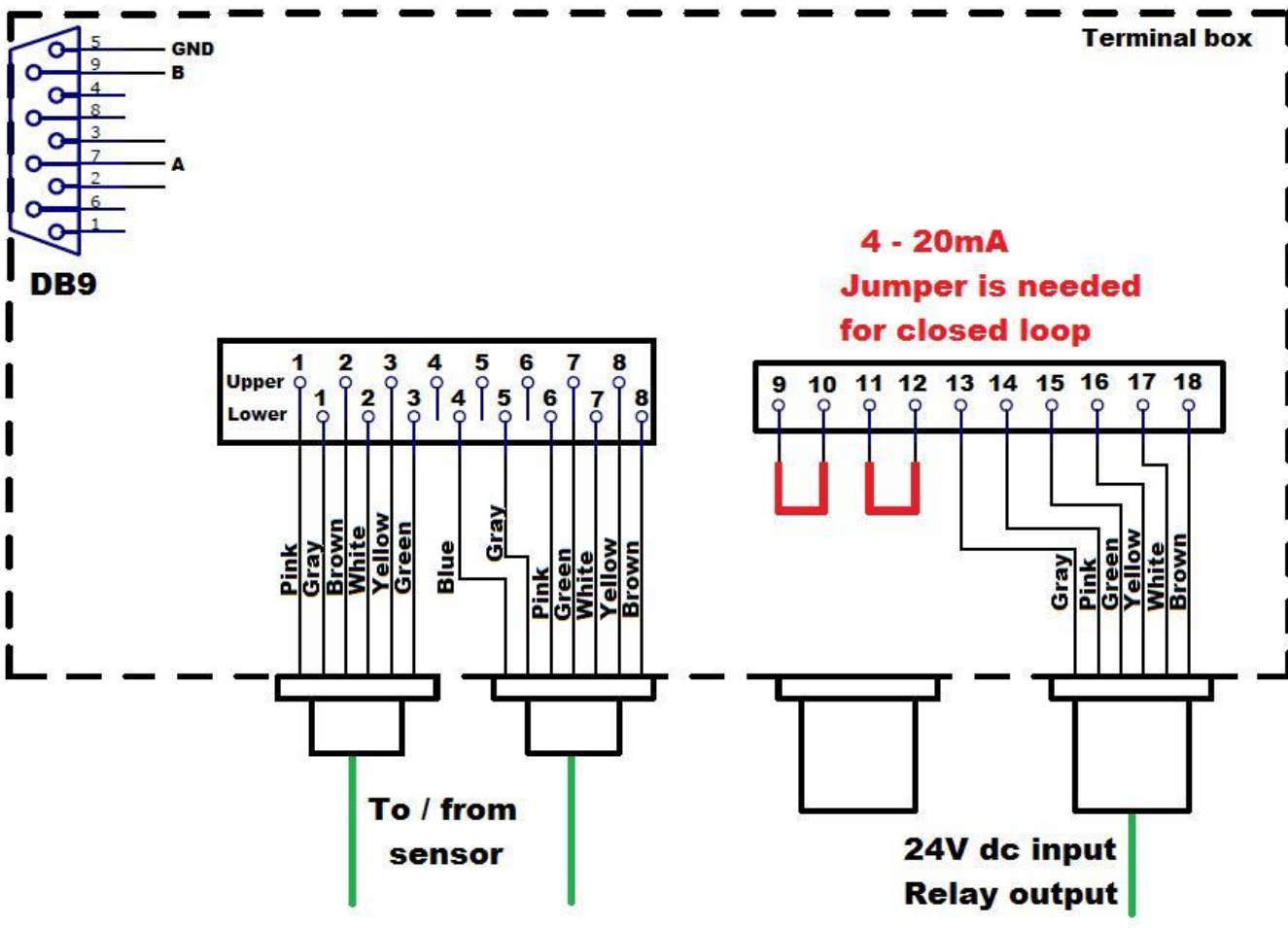



## Appendix A3: Install 2 Terminal Boxes with 3 display

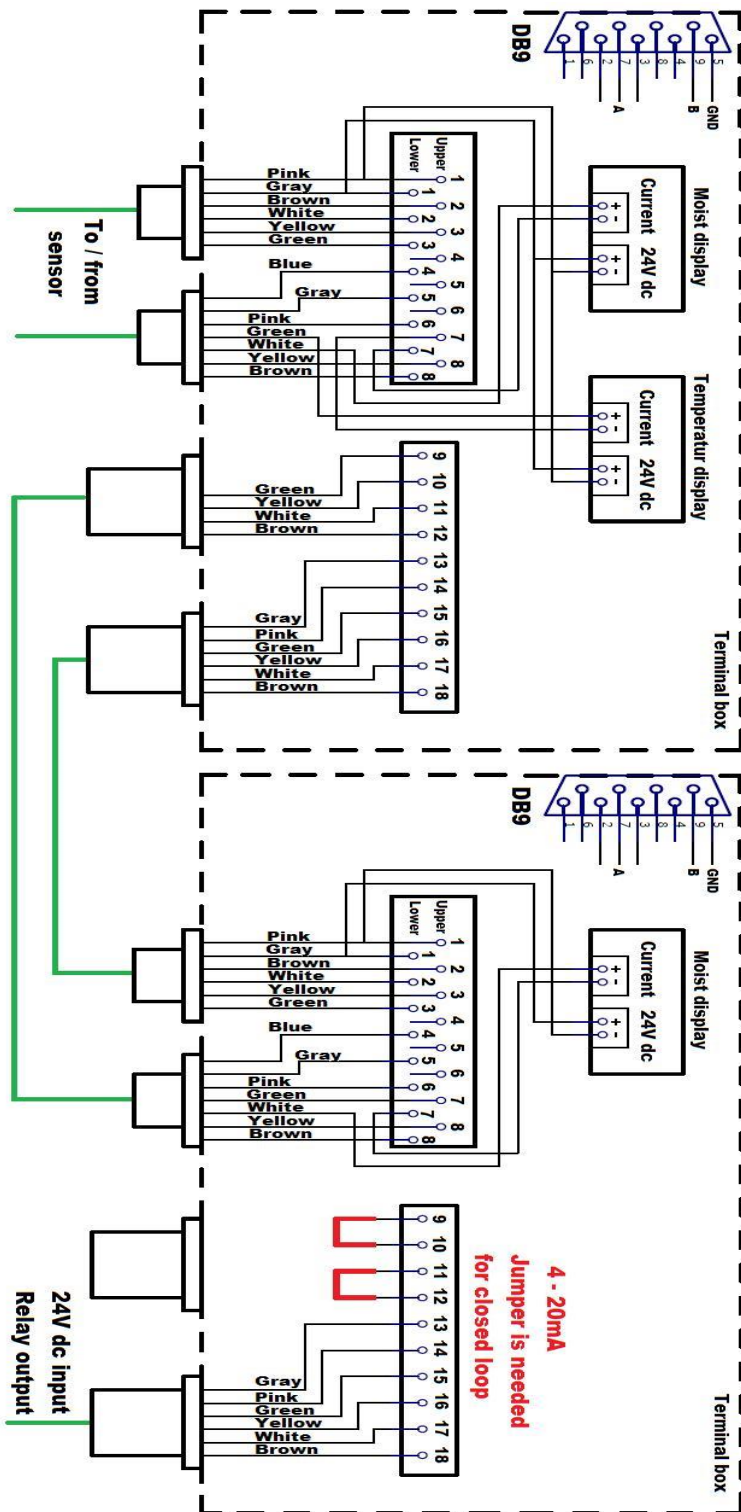





## Appendix A4: Install 2 Terminal Boxes with 1 display

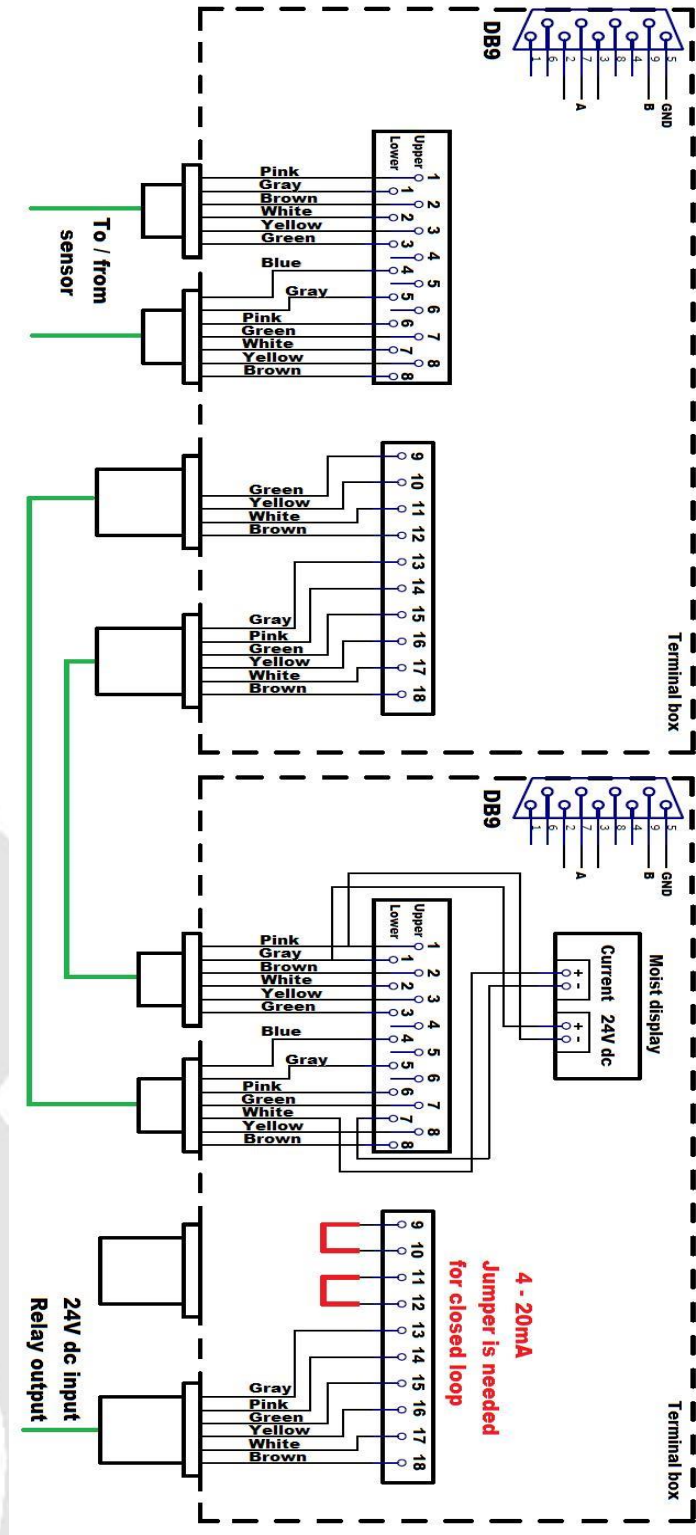



## Appendix A5: Install 2 Terminal Boxes with 2 display

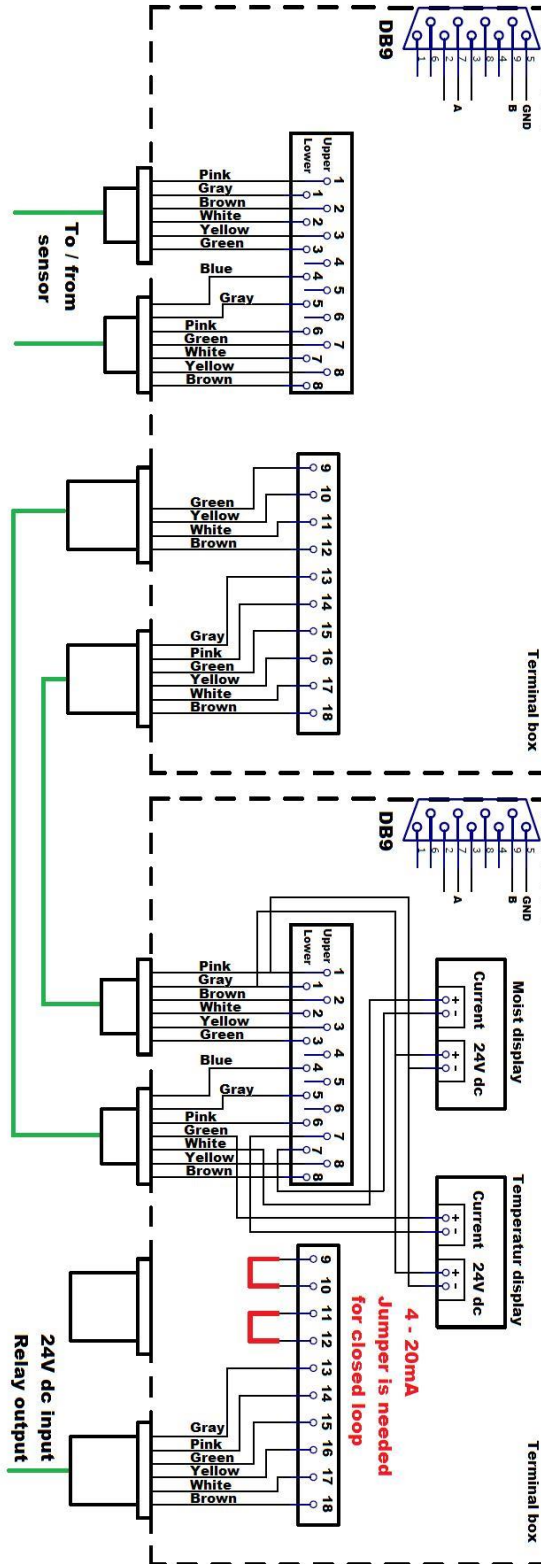



## Appendix A6: Install 3 Terminal Boxes with 4 display

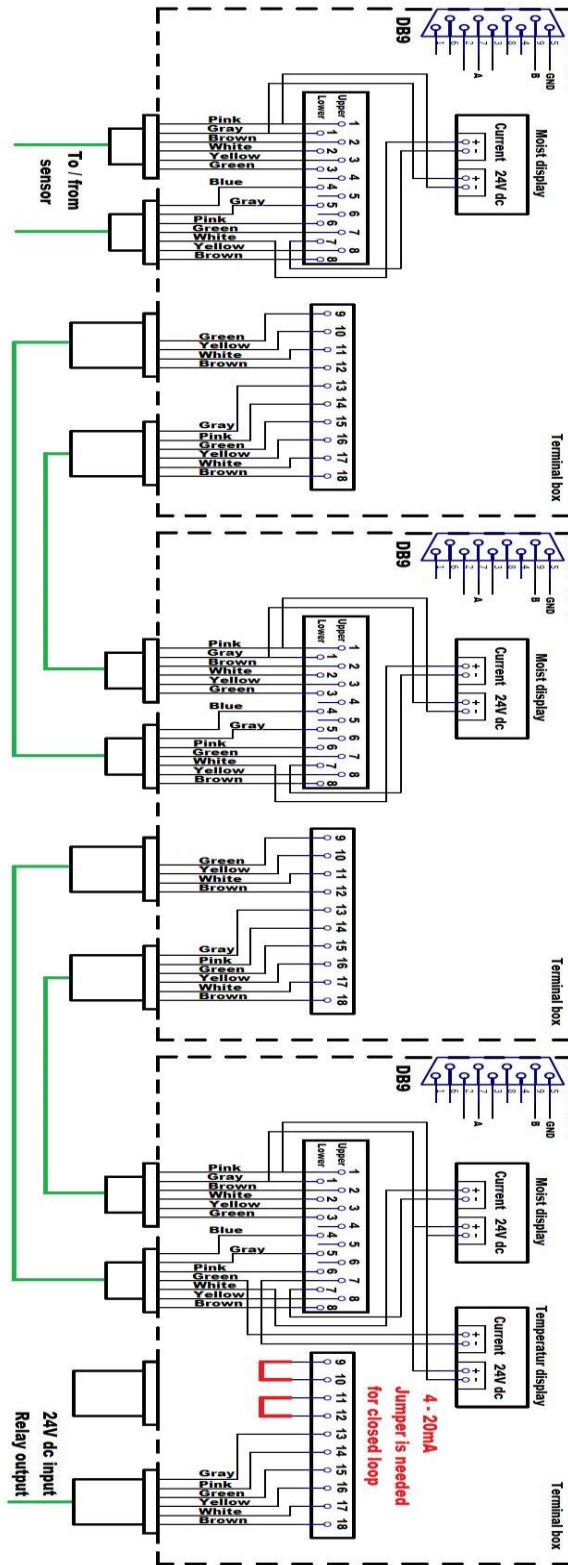



## Appendix A7: Install 3 Terminal Boxes with 3 display

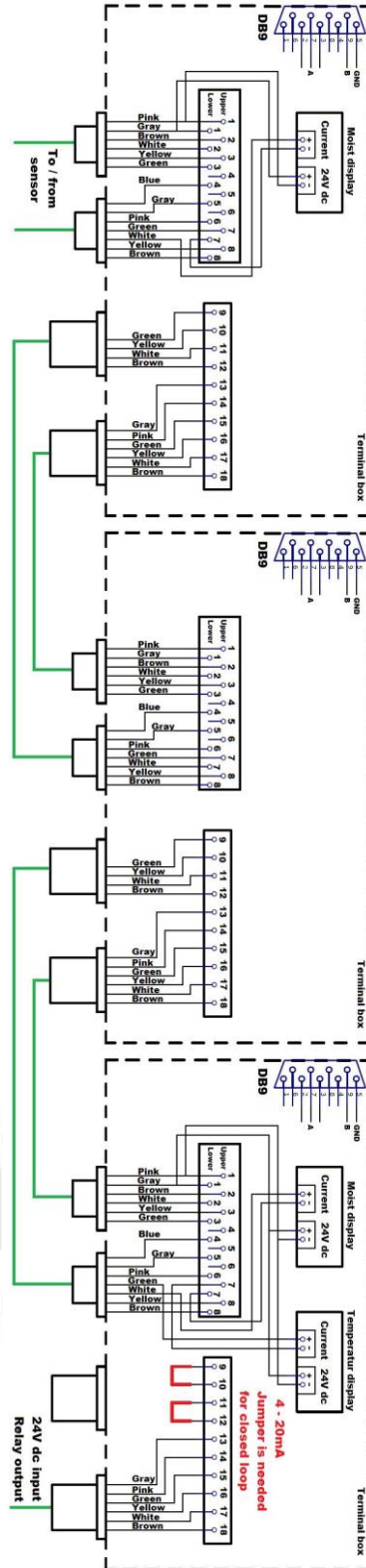



## Appendix A8: Install 3 Terminal Boxes with 2 display

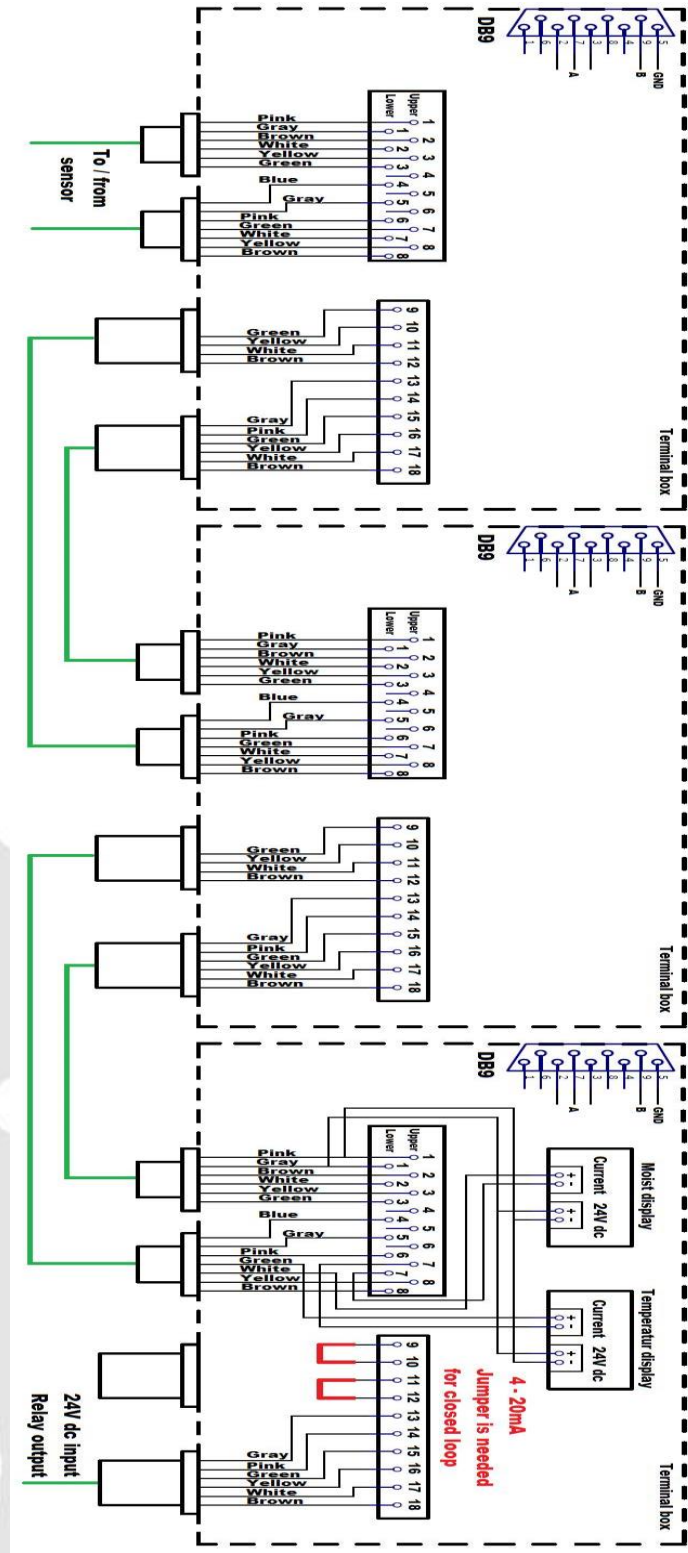



## Appendix A9: CABLE Specification

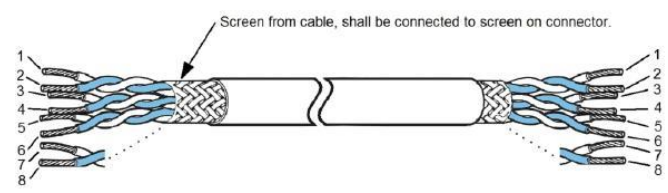
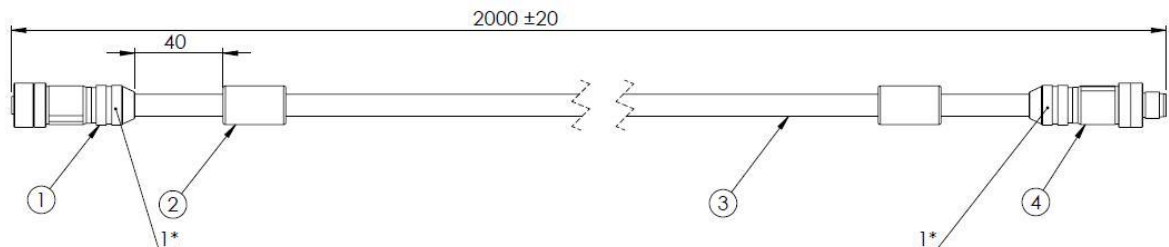

1\* - Must be ensured that these parts will not unscrew by it self. Must be tightened so that by hands it would not be possible to disassemble them.

8 pol. Connectors pin layout				
Female		Male		
	Assignment		Assignment	
	Socket		Plug	Wire
	1		1	1
	2		2	2
	3		3	3
	4		4	4
	5		5	5
	6		6	6
7	7	7		
8	8	8		

Item No.	Description	Qty.
1	Female Plug	1
4	Ferrite Core	2
2	CL105 4x2x0,75-PO – 2m	1
3	Male Plug	1



## How to adjust the display in a WIO/WIOI

When the display is adjusted by PAJ Group, it is adjusted for either **a<sub>w</sub>** or **ppm** reading.

**a<sub>w</sub>** reading:                      4 mA = .0000 a<sub>w</sub>                      20 mA = 1.0000 a<sub>w</sub>

**ppm** reading:                      4 mA = 0000 ppm                      20 mA = \* ppm

\*If a customer wishes the display to indicate ppm-values, he must specify to PAJ Group:

- The specific temperature of the sample/medium, at which, WIO/WIOI shall measure.
- Which ppm-value equals 1.00 a<sub>w</sub>, at that specific temperature.

However, a few customers wish to be able to adjust the display or change the **ppm**-value-range of the display.

Here is a description of how to do it:

**DISCLAIMER:** The warranty of WIO/WIOI is void, if you adjust the display yourself.

### Connection diagram

Make a wire connection with two power supply equipments as shown below:

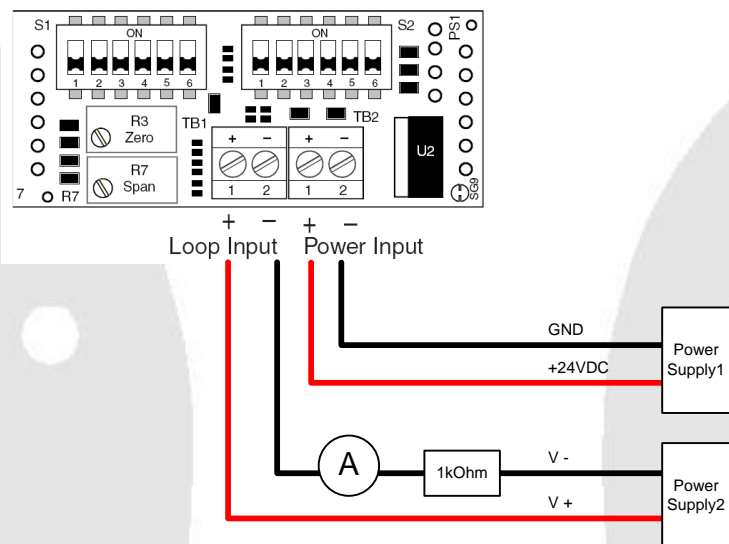

Figure 1



### Start condition

Set R3(zero point adjust) and R7(max. point / span adjust) fully clockwise, roughly 20 turns.

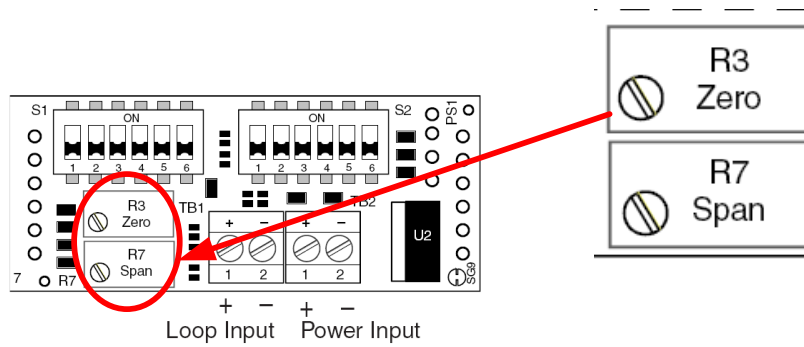

Figure 2

### Setting DIP-switches on S1 and S2:

The range/span of the display is set by DIP-switches, located on the back of the display.

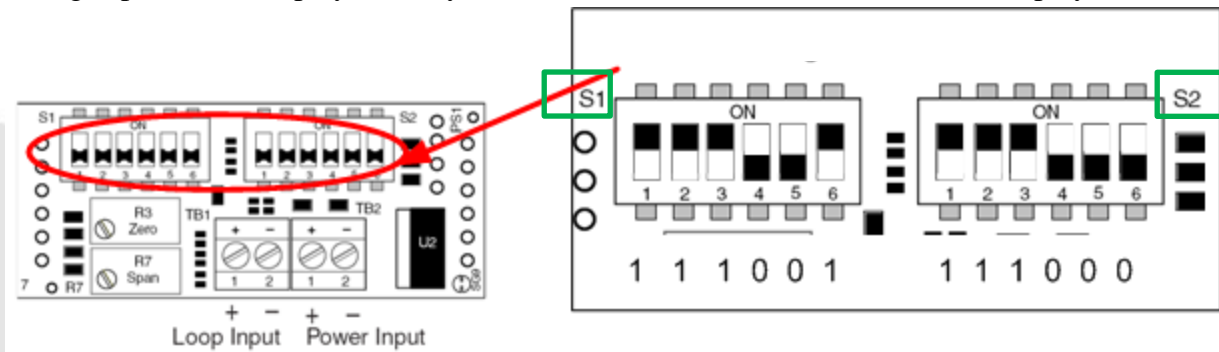

Figure 3

The display in WIO/WIOI is a newer revision, than shown in figure 3. It has a different physical appearance (figure 4), but the DIP-switches have same functionality. The switch-sliders (figure 3) are indicated as black. In reality they are white.



Figure 4





### Setting DIP-switches for a<sub>w</sub>-reading:

#### Desired readings:

4 mA = .0000 a<sub>w</sub>

20 mA = 1.0000 a<sub>w</sub>

#### DIP-switch settings (for a<sub>w</sub>):

The switch-sliders are indicated as black. In reality they are white.

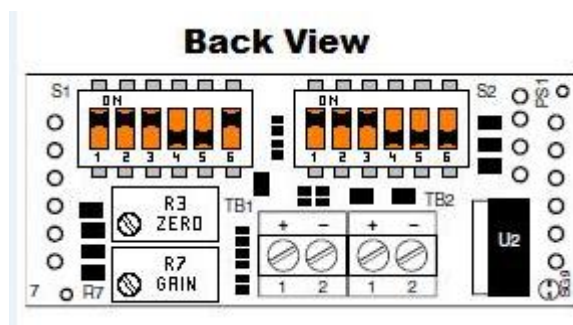

Figure 5



## Setting DIP-switches for ppm-reading:

DIP-switches must be set according to Table 1 and Table 2.

**Table 1. DIP-Switch Settings**

	Display Reading		Switch S1						Switch S2	
	4mA	20mA	SW1	SW2	SW3	SW4	SW5	SW6	SW1	SW2
1.	0000	2250-2500	Off	On	On	On	Off	Off	On	On
2.	0000	2500-2800	Off	On	On	On	Off	Off	Off	On
3.	0000	2800-3200	Off	On	On	On	Off	Off	On	Off
4.	0000	3200-3850	Off	On	On	On	Off	Off	Off	Off
5.	0000	3850-4300	On	Off	On	On	Off	Off	On	On
6.	0000	4300-4900	On	Off	On	On	Off	Off	Off	On
7.	0000	4900-5600	On	Off	On	On	Off	Off	On	Off
8.	0000	5600-6200	On	Off	On	On	Off	Off	Off	Off
9.	0000	6200-6800	Off	Off	On	On	On	Off	On	On
10.	0000	6800-7750	Off	Off	On	On	On	Off	Off	On
11.	0000	7750-8600	On	On	Off	On	On	Off	On	On
12.	0000	8600-9850	On	On	Off	On	On	Off	Off	On
13.	0000	9850-11000	On	On	On	Off	Off	On	On	On
14.	0000	11000-12000	On	On	On	Off	Off	On	Off	On
15.	0000	12000-13000	On	Off	Off	On	Off	On	On	On
16.	0000	13000-14000	On	Off	Off	On	Off	On	Off	On
17.	0000	14000-15300	On	Off	On	Off	On	On	On	On
18.	0000	15300-16300	On	Off	On	Off	On	On	Off	On
19.	0000	16300-17800	Off	Off	On	Off	On	On	On	On
20.	0000	17800-20000	Off	Off	On	Off	On	On	Off	On

**Table 2. Decimal Point Settings**

Switch S2			
SW3	SW4	SW5	SW6
DP1	DP2	DP3	DP4

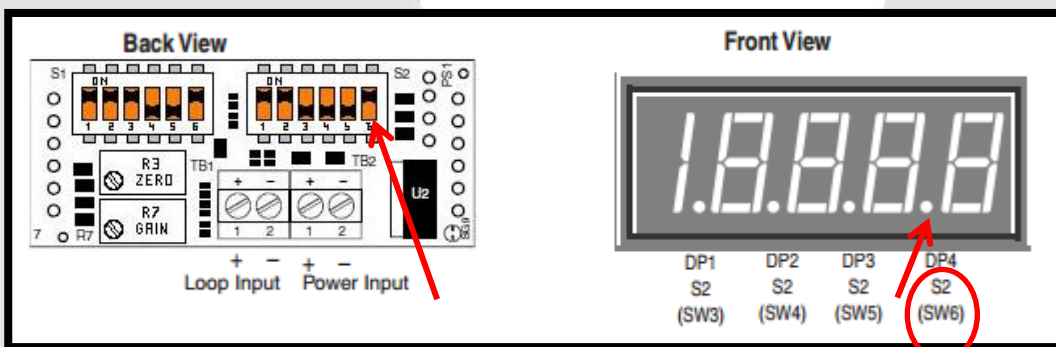

**Figure 6**

Decimal points 1 through 4 (DP1) is switched ON by setting S2/SW3 through S2/SW6 to ON (see Table 2)

Example (figure 6): Decimal point 4 (DP1) is switched ON by setting S2/SW6 to ON.



Table 1. DIP-Switch Settings

Display Reading	Switch S1						Switch S2	
	SW1	SW2	SW3	SW4	SW5	SW6	SW1	SW2
1. 0000 2250-2500	Off	On	On	On	Off	Off	On	On
2. 0000 2500-2800	Off	On	On	On	Off	Off	Off	On
3. 0000 2800-3200	Off	On	On	On	Off	Off	On	Off
4. 0000 3200-3850	Off	On	On	On	Off	Off	Off	Off
5. 0000 3850-4300	On	Off	On	On	Off	Off	On	On
6. 0000 4300-4900	On	Off	On	On	Off	Off	Off	On
7. 0000 4900-5600	On	Off	On	On	Off	Off	On	Off
8. 0000 5600-6200	On	Off	On	On	Off	Off	Off	Off
9. 0000 6200-6800	Off	Off	On	On	On	Off	On	On
10. 0000 6800-7750	Off	Off	On	On	On	Off	Off	On
11. 0000 7750-8600	On	On	Off	On	On	Off	On	On
12. 0000 8600-9850	On	On	Off	On	On	Off	Off	On
13. 0000 9850-11000	On	On	On	Off	On	On	On	On
14. 0000 11000-12000	On	On	On	Off	On	On	Off	On
15. 0000 12000-13000	On	Off	Off	On	Off	On	On	On
16. 0000 13000-14000	On	Off	Off	On	Off	On	Off	On
17. 0000 14000-15300	On	Off	On	Off	On	On	On	On
18. 0000 15300-16300	On	Off	On	Off	On	On	Off	On
19. 0000 16300-17800	Off	Off	On	Off	On	On	On	On
20. 0000 17800-20000	Off	Off	On	Off	On	On	Off	On

Table 2. Decimal Point Settings

Switch S2			
SW3	SW4	SW5	SW6
DP1	DP2	DP3	DP4
On	On	On	On

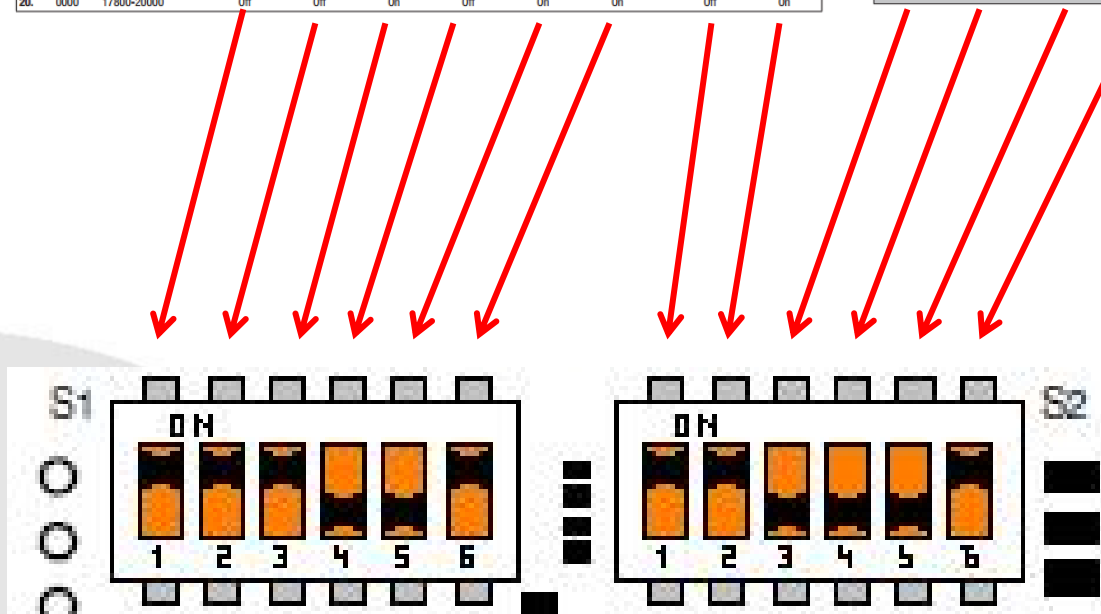

Figure 7

Since these tables can be difficult to overview, we will show a couple of examples:



Example 1:

**Desired readings:**

4 mA = 0000 ppm

20 mA = 1000.0 ppm

**DIP-switch settings:**

The switch-sliders are indicated as black. In reality they are white.

**Back View**

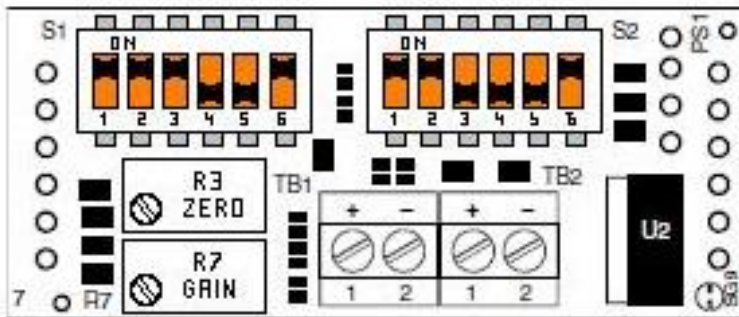

**Table 1. DIP-Switch Settings**

Display Reading	Switch S1						Switch S2	
	SW1	SW2	SW3	SW4	SW5	SW6	SW1	SW2
4mA								
20mA								
1. 0000	2250-2500	Off	On	On	On	Off	Off	On
2. 0000	2500-2800	Off	On	On	On	Off	Off	On
3. 0000	2800-3200	Off	On	On	On	Off	Off	On
4. 0000	3200-3850	Off	On	On	On	Off	Off	On
5. 0000	3850-4300	On	Off	On	On	Off	Off	On
6. 0000	4300-4900	On	Off	On	On	Off	Off	On
7. 0000	4900-5600	On	Off	On	On	Off	Off	On
8. 0000	5600-6200	On	Off	On	On	Off	Off	On
9. 0000	6200-6800	Off	Off	On	On	On	Off	On
10. 0000	6800-7750	Off	Off	On	On	On	Off	On
11. 0000	7750-8600	On	On	Off	On	On	Off	On
12. 0000	8600-9850	On	On	Off	On	On	Off	On
13. 0000	9850-11000	On	On	On	Off	Off	On	On
14. 0000	11000-12000	On	On	On	Off	Off	On	On
15. 0000	12000-13000	On	Off	Off	On	Off	On	On

**Table 2. Decimal Point Settings**

Switch S2			
SW3	SW4	SW5	SW6
DP1	DP2	DP3	DP4



Example 2:

**Desired readings:**

4 mA = 0000 ppm

20 mA = 4700 ppm

**DIP-switch settings:**

The switch-sliders are indicated as black. In reality they are white.

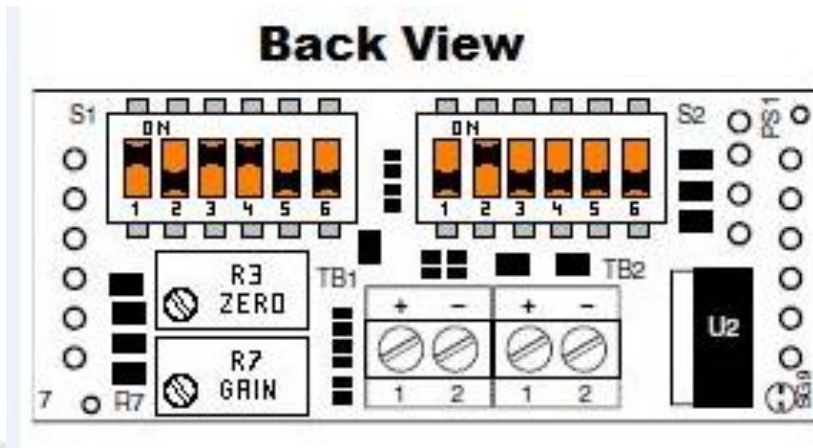

Table 1. DIP-Switch Settings

	Display Reading		Switch S1						Switch S2	
	4mA	20mA	SW1	SW2	SW3	SW4	SW5	SW6	SW1	SW2
1.	0000	2250-2500	Off	On	On	On	Off	Off	On	On
2.	0000	2500-2800	Off	On	On	On	Off	Off	Off	On
3.	0000	2800-3200	Off	On	On	On	Off	Off	On	Off
4.	0000	3200-3850	Off	On	On	On	Off	Off	Off	Off
5.	0000	3850-4300	On	Off	On	On	Off	Off	On	On
6.	0000	4300-4900	On	Off	On	On	Off	Off	Off	On
7.	0000	4900-5600	On	Off	On	On	Off	Off	On	Off
8.	0000	5600-6200	On	Off	On	On	Off	Off	Off	Off
9.	0000	6200-6800	Off	Off	On	On	On	Off	On	On
10.	0000	6800-7750	Off	Off	On	On	On	Off	Off	On
11.	0000	7750-8600	On	On	Off	On	On	Off	On	On
12.	0000	8600-9850	On	On	Off	On	On	Off	Off	On
13.	0000	9850-11000	On	On	On	Off	Off	On	On	On
14.	0000	11000-12000	On	On	On	Off	Off	On	Off	On
15.	0000	12000-13000	On	Off	Off	On	Off	On	On	On

Table 2. Decimal Point Settings

Switch S2			
SW3	SW4	SW5	SW6
DP1	DP2	DP3	DP4



## Zero point adjustment

Set PowerSupply1 to 24VDC and switch ON.

Set PowerSupply2 to 4V ( $1V/(1k\Omega + R_{display}) = 1mA$ ) and switch ON.

Adjust PowerSupply2 until the Ampere meter indicates 4.00 mA.

Adjust R3 potentiometer until the display reads "0000"

## Max. point adjustment

Set PowerSupply2 to 20V.

Adjust PowerSupply2 until the Ampere meter indicates 20.00 mA.

Notice: The signal from the WIO/WIOI Sensor to the Terminalbox/display, is as follows:

$20\text{ mA} = 1.0000\text{ a}_w = 100\% \text{RH}$  (=)\* The desired max.-ppm-value adjusted on display

\*ppm-displayadjustment will only be correct at 1 specific temperature measured in a medium, which has the desired max.-ppm-value (= 1.0 a<sub>w</sub>) at this specific temperature.

Adjust R7 potentiometer until the display reads "1.0000" (or **desired max.-ppm-value**), as shown below:



## END OF SETTING

Remove the display from power supply equipments.



The display is now ready for reading the analog signal from 4mA up to 20mA and it is configured for the indication



from 0.0000 to 1.0000 a<sub>w</sub> or

from 0000 to desired max.-ppm-value



## Appendix A10: Error / failure FAQ

Failure type	Description	Possible reasons
PPM display failure	Display shows only negative numbers 	<ol style="list-style-type: none"> <li>1. Sensor is not connected.</li> <li>2. The error caused by missing jumper in terminal box pin 11 and pin 12. See Appendix A1</li> <li>3. Check that the jumper is properly installed, it is seen that the jumper has been installed but the jumper had no proper connection</li> <li>4. The wires are reversed in terminal box pin 7 and pin 8 lower part. After changing and there is no change in the display, then the fault is either 1, 2 or 3.</li> </ol>
a <sub>w</sub> display failure	Display shows only negative numbers 	<ol style="list-style-type: none"> <li>1. Sensor is not connected.</li> <li>2. The error caused by missing jumper in terminal box pin 11 and pin 12. See Appendix A1</li> <li>3. Check that the jumper is properly installed, it is seen that the jumper has been installed but the jumper had no proper connection</li> <li>4. The wires are reversed in terminal box pin 7 and pin 8 lower part. After changing and there is no change in the display, then the fault is either 1, 2 or 3.</li> </ol>

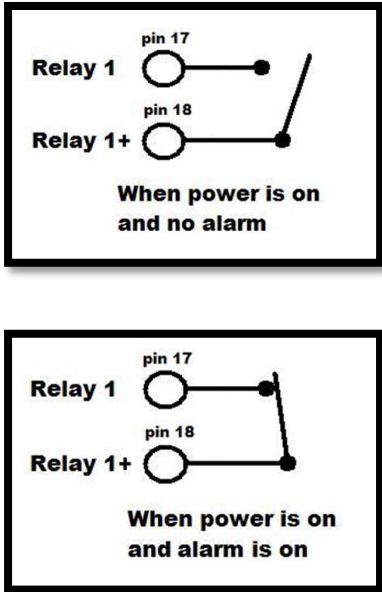
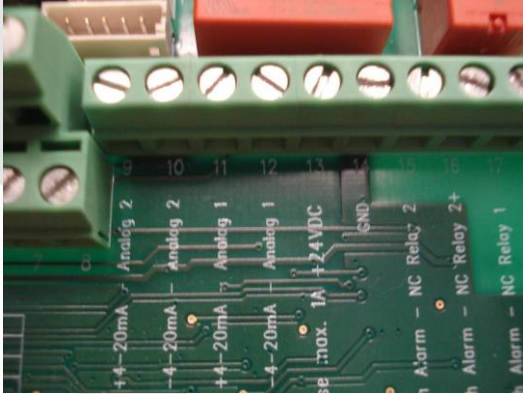
<p>Dead display</p>	<p>Display indicate nothing</p> 	<p>Maybe is 24V dc supply interrupted to the display. There shall be 24V dc at this connector.</p> 
<p>Relay</p>	<p>Relay-state while alarm is on</p>	
<p>Sensor</p>	<p>How to check the mA output from sensor?</p> 	<p>Remove jumper in pin 11 and pin 12. In order to ensure that there can be measured mA must pin 11 and pin 12 must be screwed. Remember to set the measuring instrument in dc mA and connect test leads correctly in the measuring instrument. Sensor is alright when measuring a value between 4 and 20 mA. Is the result about 2 mA then there is an internal sensor error, so the sensor must be sent for repair. Is the result 0 mA, tjek if the sensor get 24 Vdc power.</p>



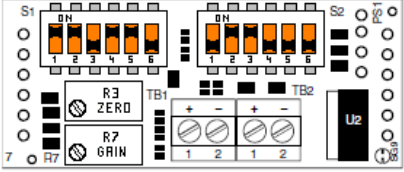
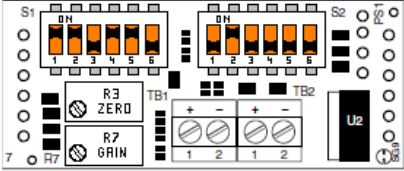

Dip Switch a <sub>w</sub>	Are the dip switches still positioned correctly?	Correct positions:  <p style="text-align: center;"><b>Back View</b></p> 
Dip Switch PPM	Are the dip switches still positioned correctly?	Correct positions:  <p style="text-align: center;"><b>Back View</b></p> 
Broken cables between Sensor and terminal box	No mA will can be measured on:  Analog 1: Terminal 11 and 12 and Analog 2: Terminal 9 and 10	



## ***Company Information***

PAJ Sensor A/S  
Grundtvigsallé 163  
DK-6400 Sønderborg  
Tel: (0045) 7443 7181  
Mail: paj@paj.dk



D80-105-0020-00