



WIO300 and WIOI300 Water in oil sensor

INSTALLATION MANUAL Rev. 1.07

111881-923 Rev. 1.07 WIO300 Installations manual

Date: 2017-01-20





Contents

Contents	2
Introduction	3
Pin assignment of the terminal box connector for customer	5
Pin assignment of the terminal box connector for WIO-sensor.....	6
Pin assignment of the WIO300 sensor	8
WIO-sensor cable specification	9
Cable requirements for EMC.....	9
Cable installation	10
Terminal box wiring example 1 (230 Vac)	12
Terminal box wiring example 2 (24Vdc)	12
Terminal box wiring example 3 (24Vdc)	13
Installation of 1 Terminal Box with 1 display.....	13
Drilling distances for the terminal box.....	15



Introduction

Only use the manufacturer specified cable for connecting the WIO-sensor with the terminal box.

The connections of the external cables are based on the special IP66- cable glands for the power supply, relay contacts, and analog outputs, respectively.

Connecting the devices must be performed only by qualified and trained professionals!

The WIO-Sensor can be extended with up to three terminal boxes.

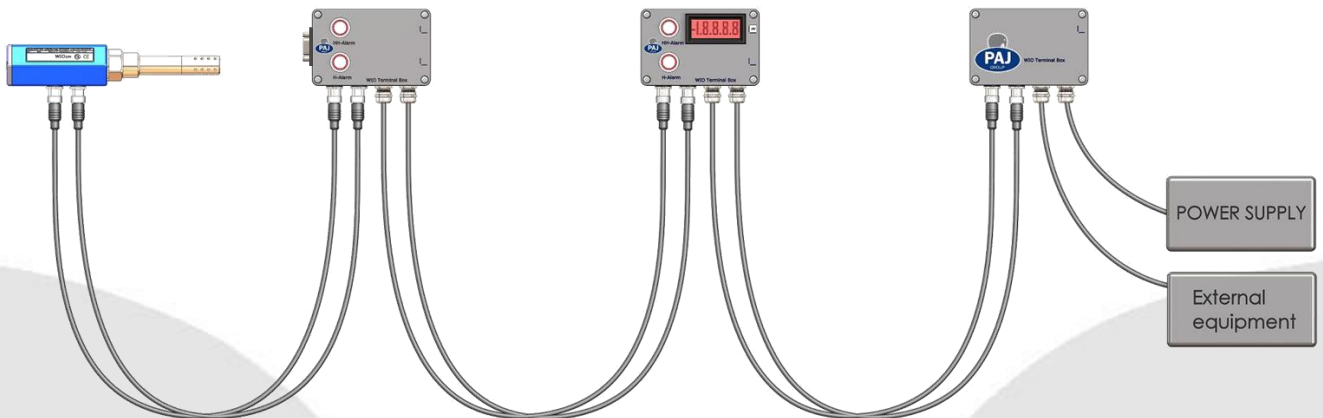

Total cable length for RS232 communication: WIO Sensor – Terminal Box with D-subminiature – PC, must not be longer than 15 meters. Example: Distance between WIO sensor and box with D-subminiature 10 meters, distance between D-subminiature connector to PC 5 meters, total length 15 meters.

The distance between the boxes and sensor shall not be longer than 50 meters.

Only the last connected box can be connected to the power supply and the analog output, as shown in the figure above.



WIO Standard 3/4" (ISO 228-1 G3/4"), Short



WIO Standard 1/2" (ISO 228-1 G1/2"), Short



WIO Ball Valve pipe, Long



WIO Integrated, Short pipe



WIO Integrated, Long pipe



Pin assignment of the terminal box connector for customer

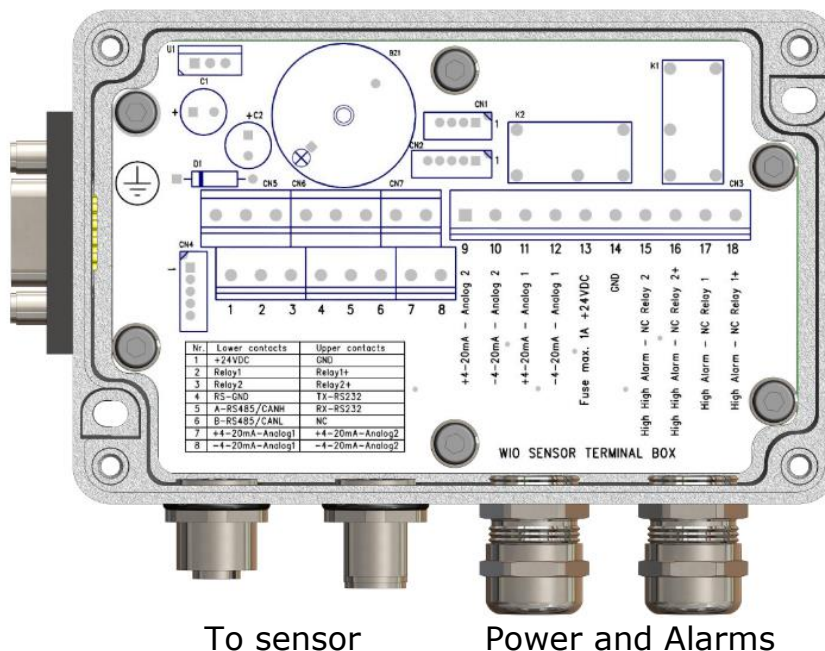

There is only one connector, CN3, for using of the terminal box contacts

Contact-No.	Description
9	+4 – 20 mA positive analog output signal for indication of temperature in oil. The jumper should only be removed if the analog signal is used in following unit or external device. Otherwise this contact is connected to contact no. 10.
10	-4 – 20 mA return analog signal for indication of temperature in oil. The jumper should only be removed if the analog signal is used in following unit or external device. Otherwise this contact is connected to contact no. 9.
11	+4 – 20 mA positive analog output signal for indication of Aw or PPM in oil. The jumper should only be removed if the analog signal is used in following unit or external device. Otherwise this contact is connected to contact no. 12.
12	-4 – 20 mA return analog signal for indication of Aw or PPM in oil. The jumper should only be removed if the analog signal is used in following unit or external device. Otherwise this contact is connected to contact no. 11.
13	Power supply, 24VDC \pm 10% and with max. residual voltage ripple 10%
14	Power supply ground terminal contact
15	Relay contact for HH alarm
16	Relay contact for HH alarm
17	Relay contact for H alarm
18	Relay contact for H alarm



Pin assignment of the terminal box connector for WIO-sensor

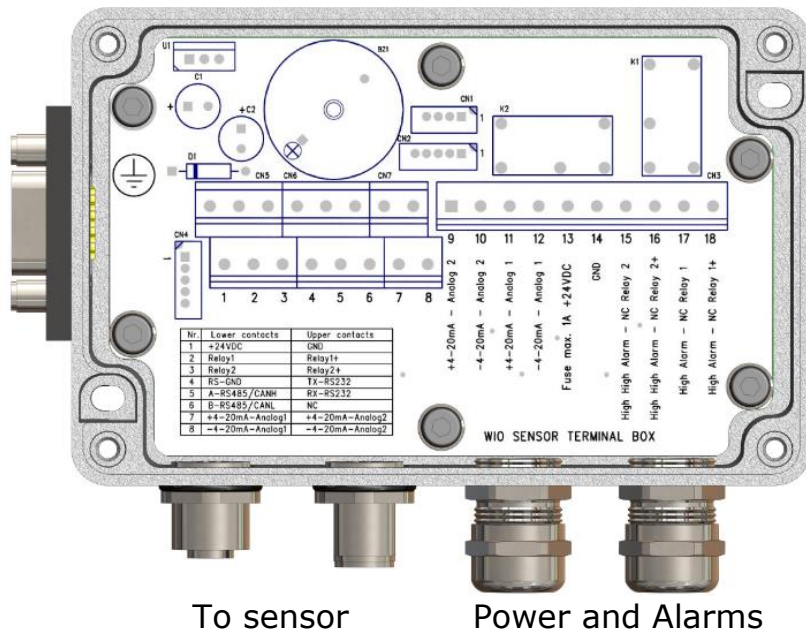

8 pol. Connectors pin layout

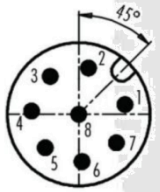
Female				Male			
Female illustration	Assignment			Male illustration	Assignment		
	1	White	Relay1		1	White	+4-20mA - Analog1
	2	Brown	Relay1+		2	Brown	-4-20mA - Analog1
	3	Green	Relay2		3	Green	+4-20mA - Analog2
	4	Yellow	Relay2+		4	Yellow	-4-20mA - Analog2
	5	Gray	+24 VDC		5	Gray	TX-RS232
	6	Pink	GND		6	Pink	RX-RS232
	7	Blue	NC		7	Blue	RS-GND
	8	Red	NC		8	Red	NC



Pin assignment of D-Sub9 connector

Communication

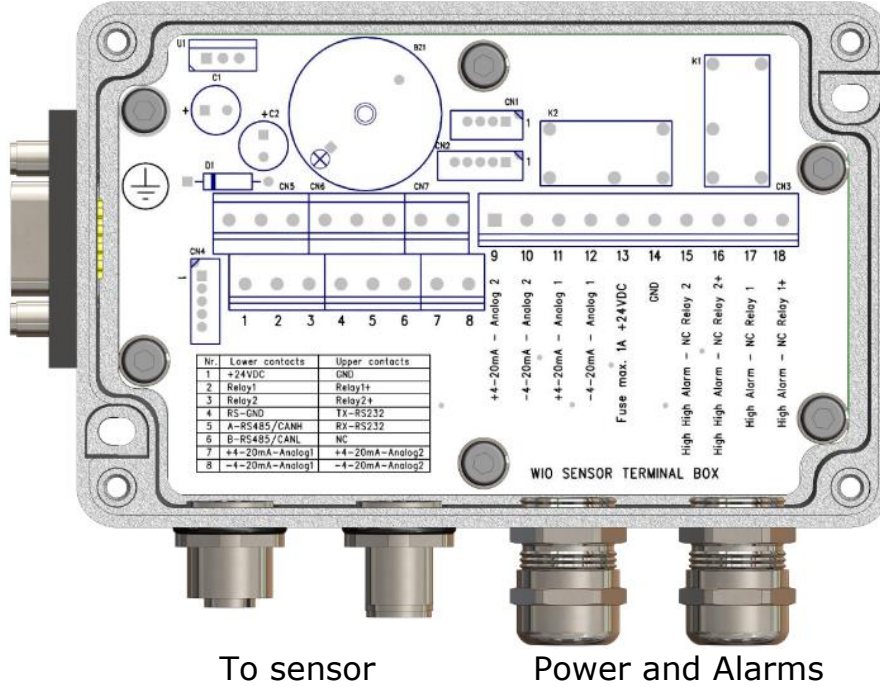

To sensor

Power and Alarms

DB9 connector pin layout			
Illustration	Assignment		
	1	NC	-
	2	Yellow	TX-RS232
	3	Green	RX-RS232
	4	NC	-
	5	Black	RS-GND
	6	NC	-
	7	NC	-
	8	NC	-
	9	NC	-

Max length of communication cable – 15 meters.

Pin assignment of the WIO300 sensor

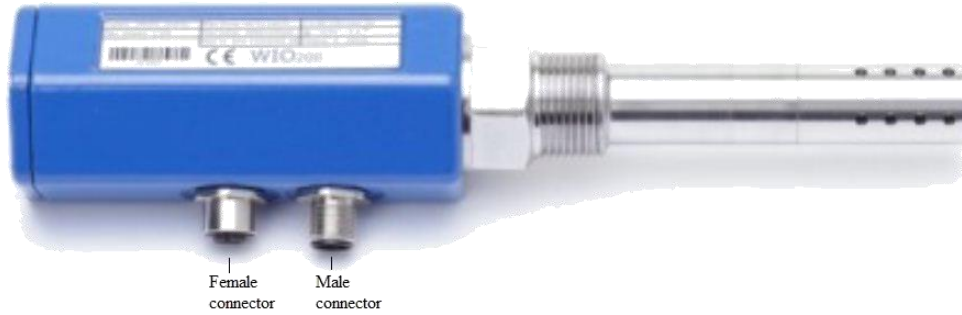

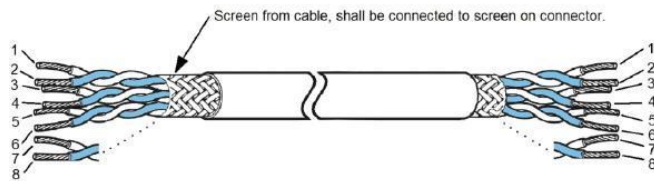
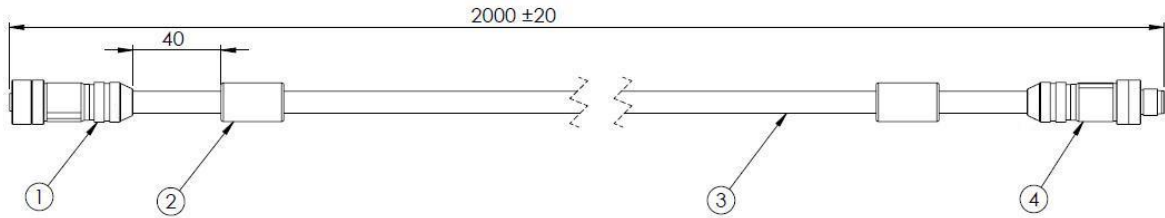

Figure: WIO-sensor connectors

8 pol. Connectors pin layout							
Male				Female			
Male illustration	Assignment			Female illustration	Assignment		
	1	White	Relay1		1	White	+4-20mA - Analog1
	2	Brown	Relay1+		2	Brown	-4-20mA - Analog1
	3	Green	Relay2		3	Green	+4-20mA - Analog2
	4	Yellow	Relay2+		4	Yellow	-4-20mA - Analog2
	5	Gray	+24 VDC		5	Gray	TX-RS232
	6	Pink	GND		6	Pink	RX-RS232
	7	Blue	NC		7	Blue	RS-GND
	8	Red	NC		8	Red	NC



WIO-sensor cable specification



8 pol. Connectors pin layout			
Female		Male	
A	Assignment	B	Assignment
Socket	Wire	Plug	Wire
1	1	1	1
2	2	2	2
3	3	3	3
4	4	4	4
5	5	5	5
6	6	6	6
7	7	7	7
8	8	8	8

Item No.	Description	Qty.
1	Female Plug	1
4	Ferrite Core	2
2	CL 105 4x2x0.75-PO – 2m	1
3	Male Plug	1

Cable requirements for EMC

When connecting cables to the WIO/WIOI sensor terminal boxes, PAJ Group recommends to use:

- \varnothing 6-12 mm cables (IP66 compliance)
- Cables with braided and foil shielding, with at least 85% coverage (EMC compliance).
- Ferrite beads with inner diameter appropriate to the chosen cable, 28 mm length, and \varnothing 17.5mm outer diameter, King Electronics supplier.

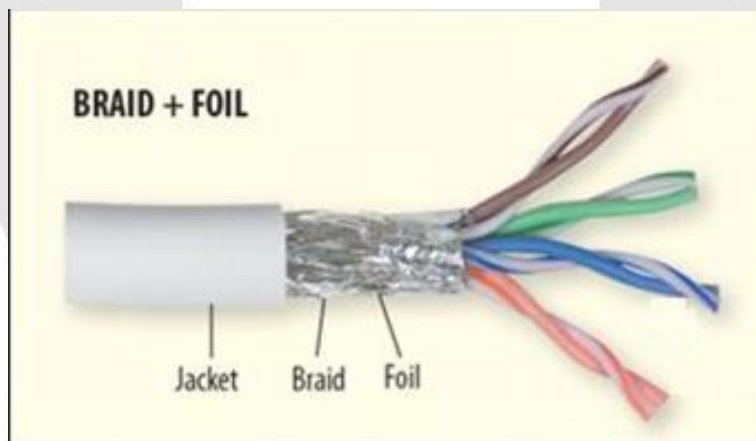

PAJ Sensor A/S • Grundtvigs Allé 163 • DK-6400 Sønderborg

Tel: +45 74 43 71 81 • Fax: +45 74 43 71 91 • CVR: 3459-1229 • www.paj-sensor.com • e-mail: paj@paj.dk
 APPROVALS: ISO 9001, ISO 14001, ISO 13485, IRIS, IEC 61340-51 & IPC-A-610 CLASS 3



Cable installation

Using cable specifications any different than the recommended ones may lead the product to be non-IP66 or EMC compliant. Also the cable shielding should be connected to the M20 glands in a specific way, in order to maintain EMC compatibility.

The pictures serve only demonstrational purposes. Actual installation may vary according to each terminal box and /or customer cables.

Remove cable insulation as needed to connect to the terminal box. Then cut cable shielding to 25mm.

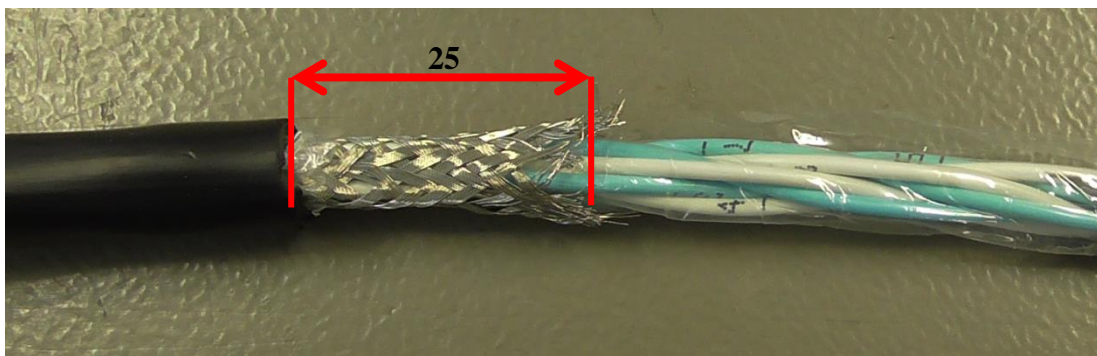

Remove the metal pressing nut from the M20 Gland and plastic pinch ring and install them on the cable. It is recommended to install a ferrite bead first, with the specifications mentioned earlier.



Roll the cable shielding back on the plastic pinch ring installed previously, then install the cable in the M20 gland. Ensure that the cable shield makes contact with the M20 gland evenly, in the 360° of the periphery.



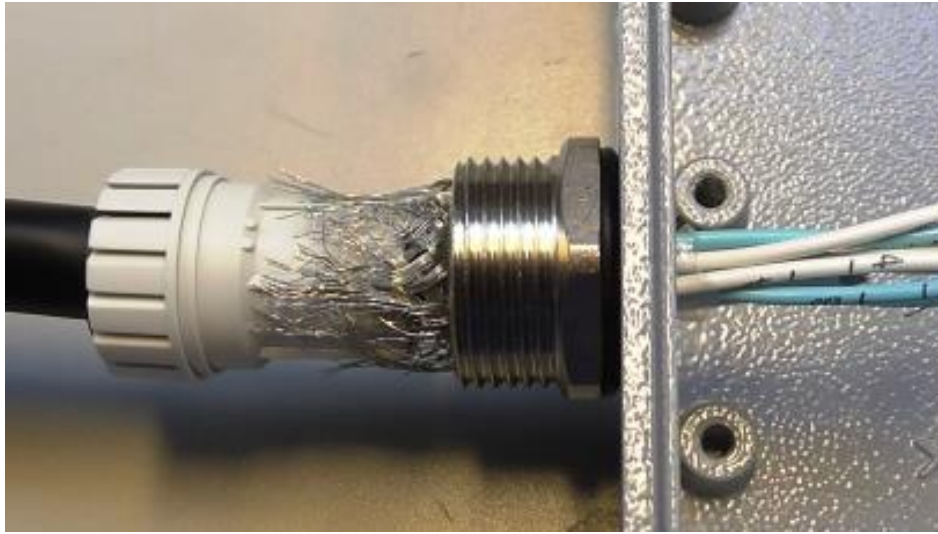

Install the pressing nut on the M20 gland and torque to 8 Nm.

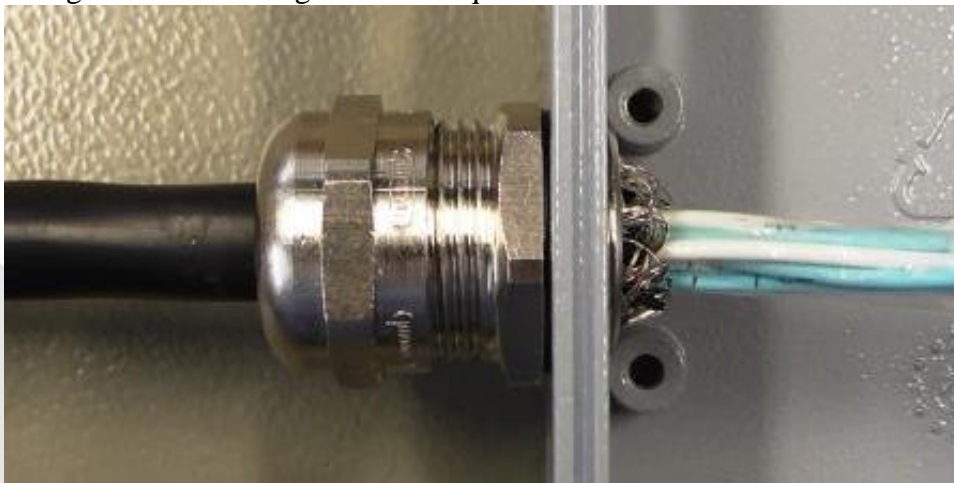

These are the generic steps to be taken in order to ensure EMC compatibility of the WIO Sensor. They should be followed wherever cables go from the device itself to any of the users other devices.



Terminal box wiring example 1 (230 Vac)

This is a 230Vac setup, there is 230Vac on L1 & N. There is 24Vdc at Terminal Box 13 & 14. There is no alarm. The lamps are off, everything is OK.

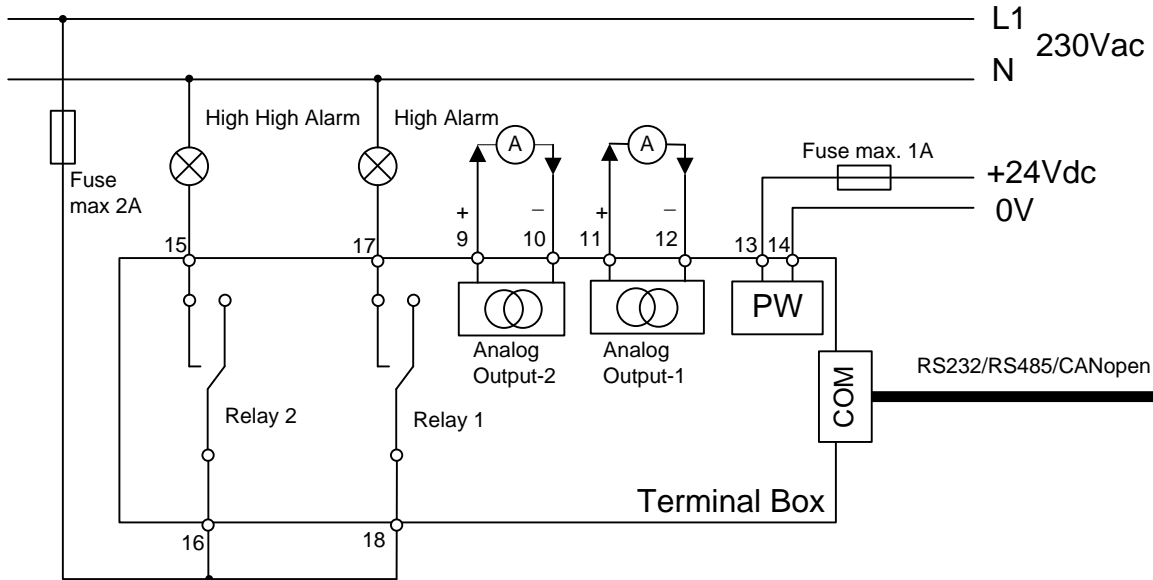

Terminal box wiring example 2 (24Vdc)

This is a 24Vdc setup, there is no alarm. The lamps are off, everything is OK.

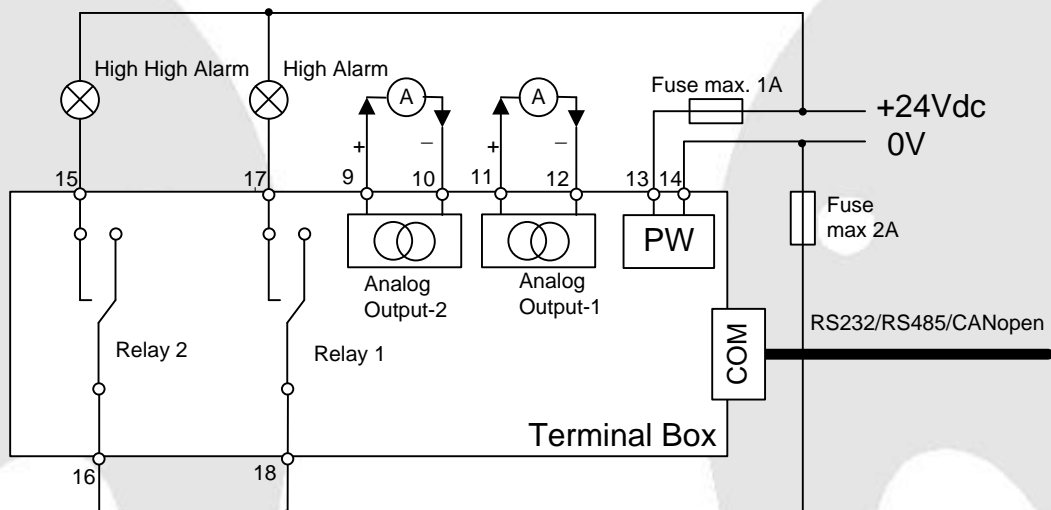



Terminal box wiring example 3 (24Vdc)

This is a 24Vdc setup, there is no alarm. The OK lamps are lit and everything is OK.

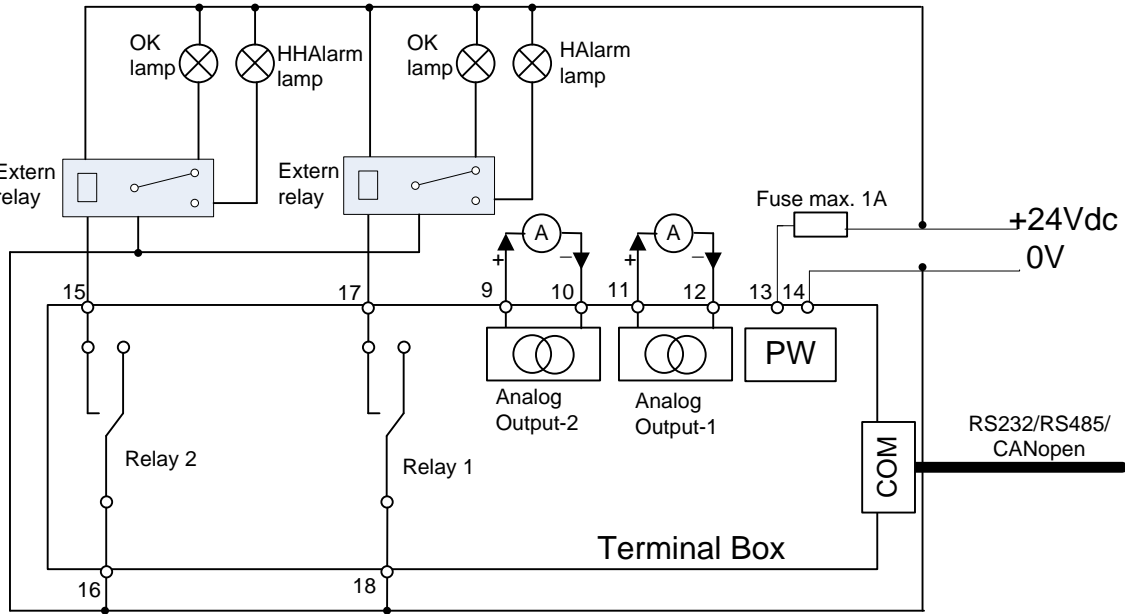

Installation of 1 Terminal Box with 1 display

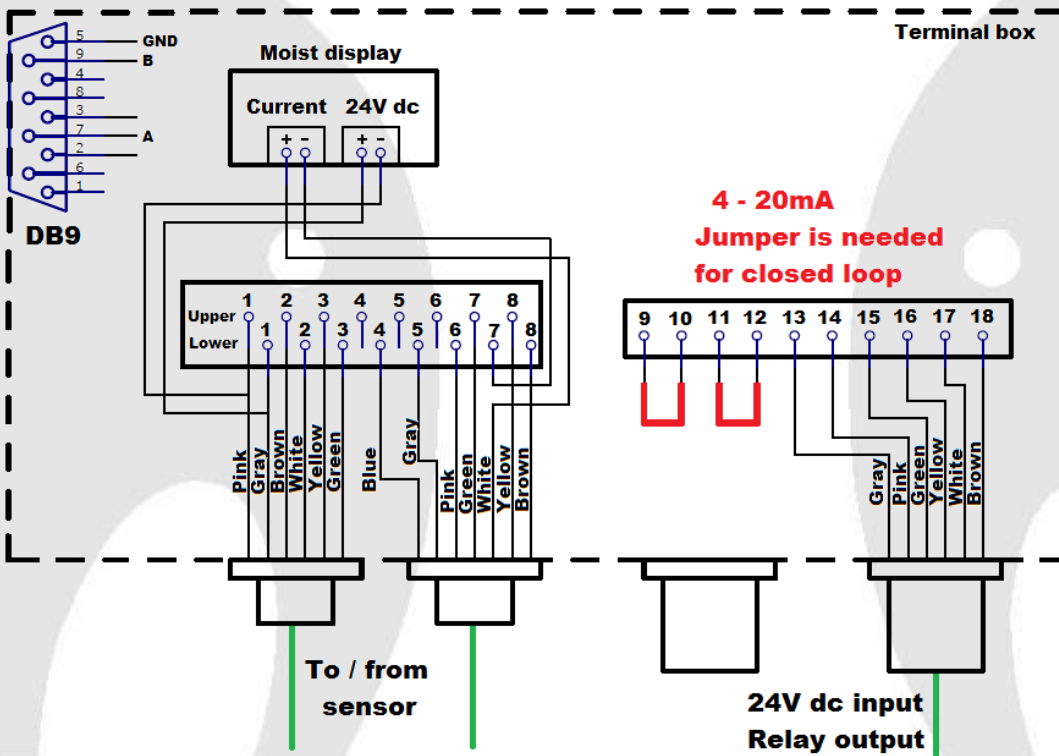



(Installation of 2 Terminal Boxes with 2 displays)

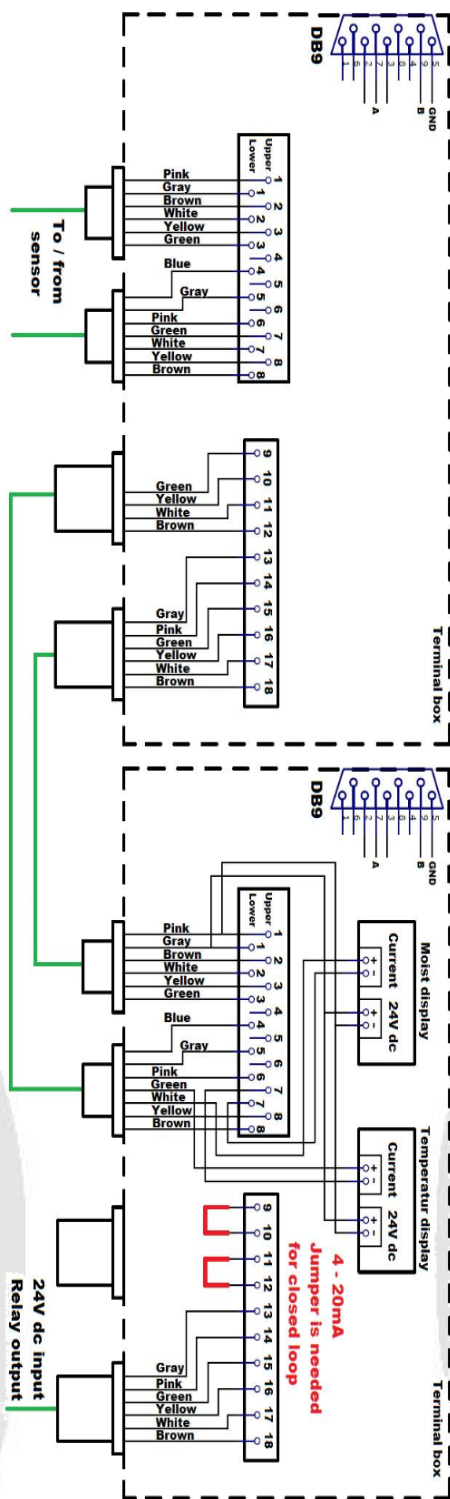

More examples are shown in the user manual.



Drilling distances for the terminal box

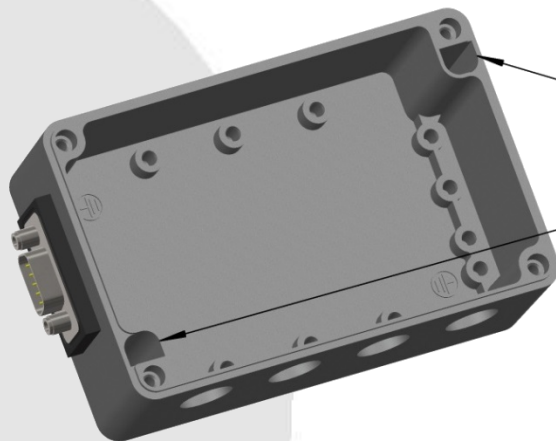
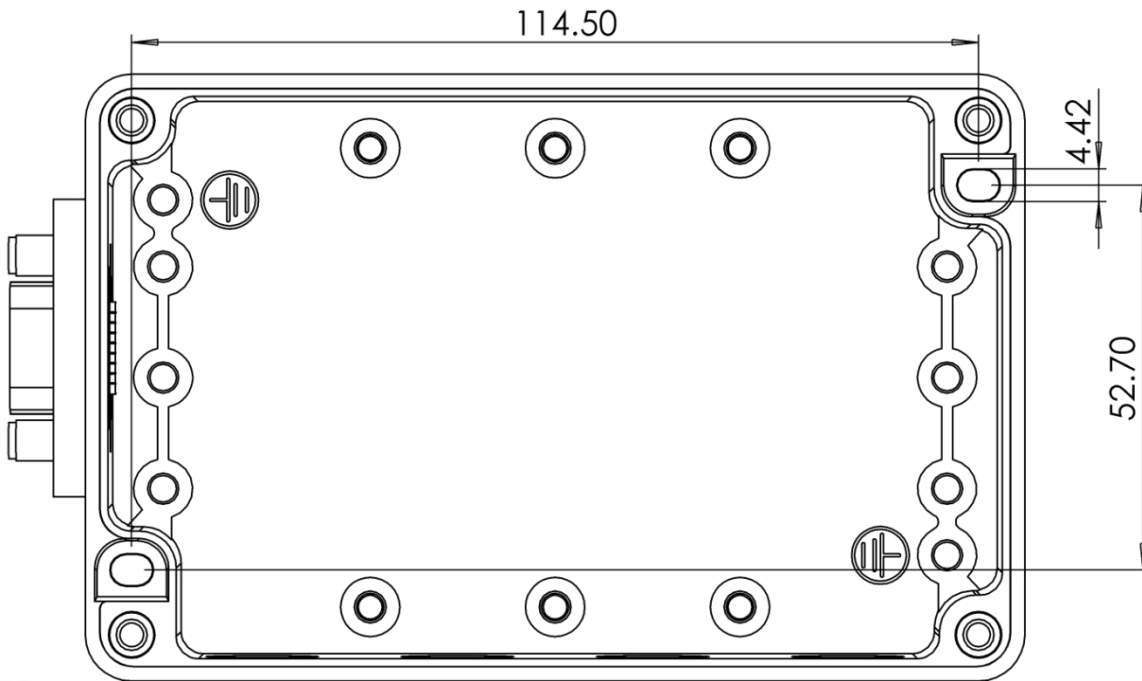

2x Mounting holes



WIO Sensor dimensions in mm

WIO Standard 1/2" thread Sensor, Short dimensions in mm:

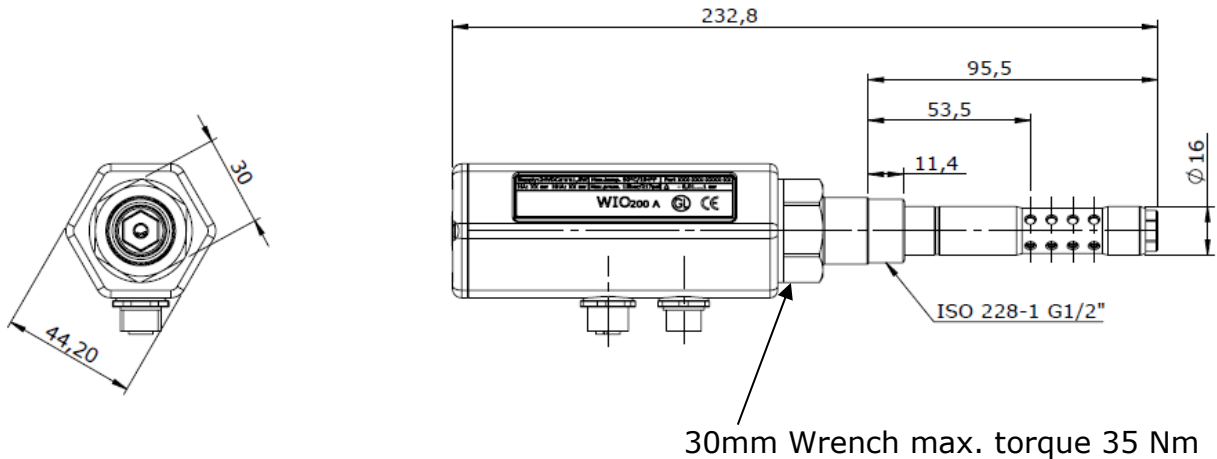

WIO Standard 3/4" thread Sensor, Short dimensions in mm:

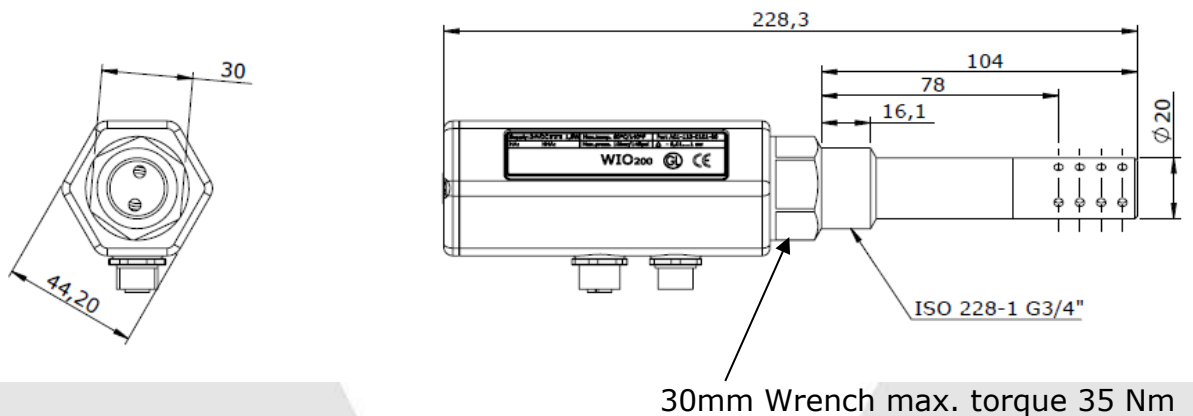

WIO Ball Valve pipe 1/2" thread Sensor, Long dimensions in mm:

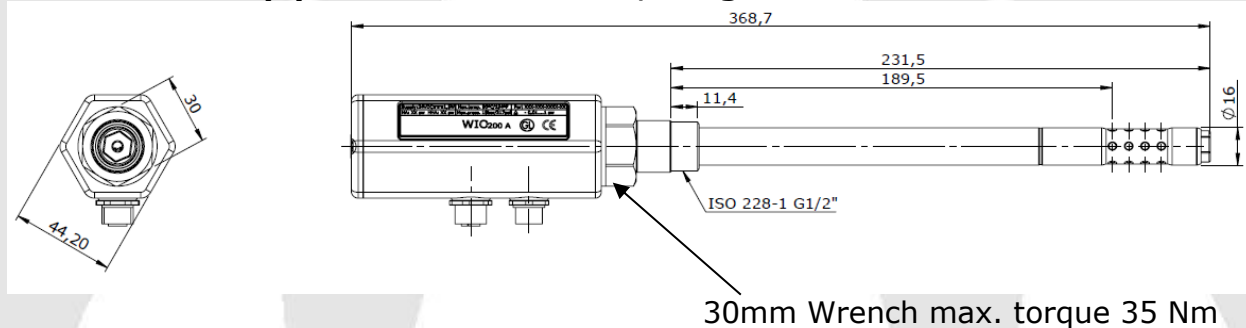



WIO Ball Valve pipe 3/4" thread Sensor, Long dimensions in mm:

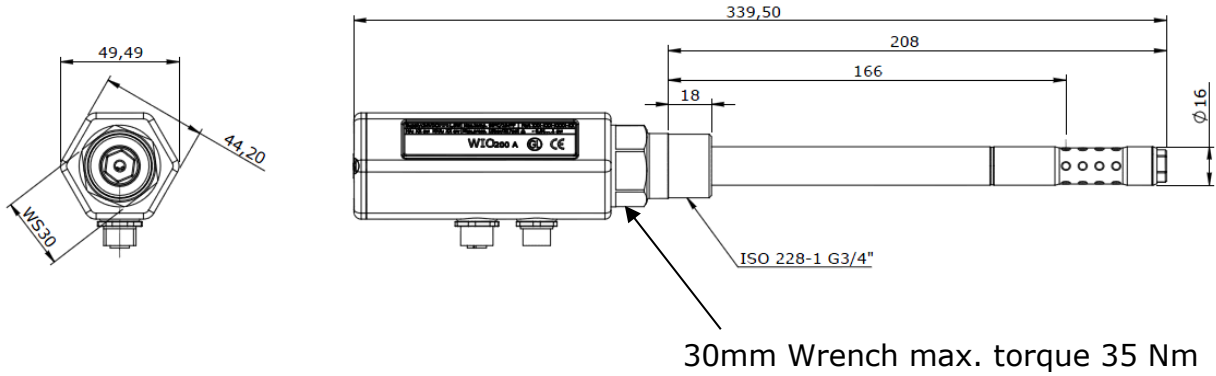

Terminal box dimensions in mm

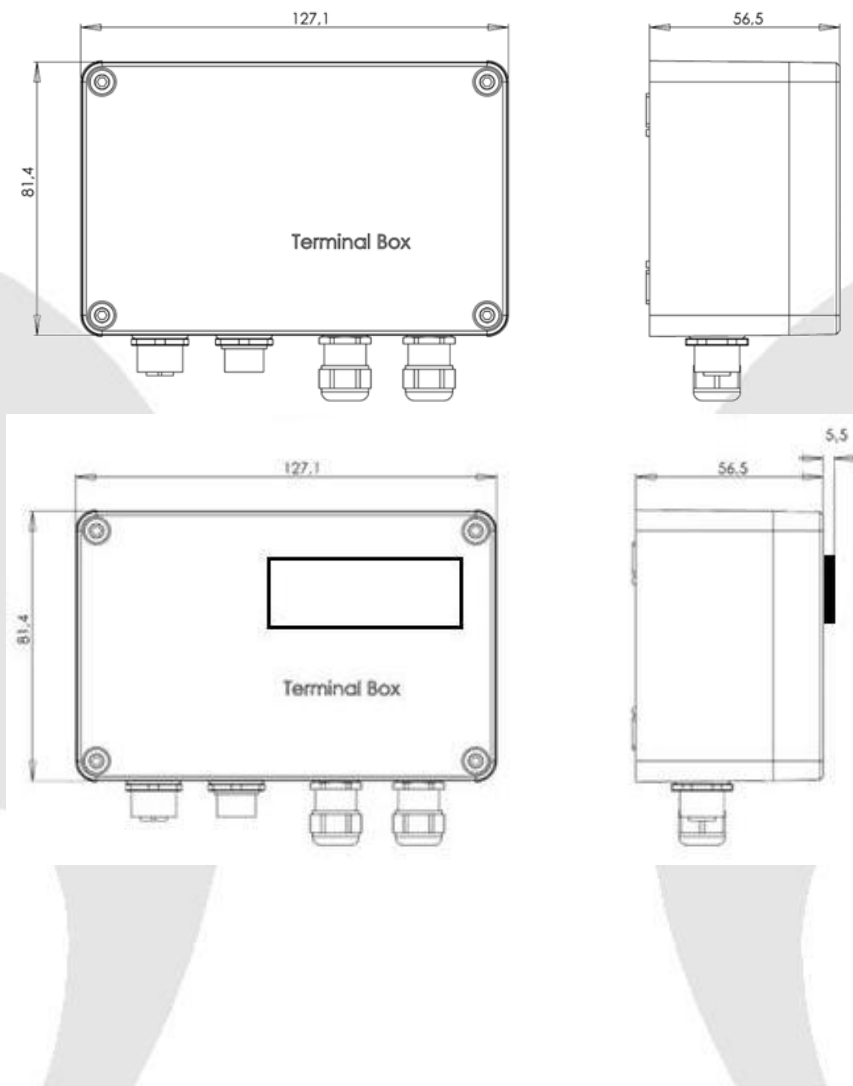

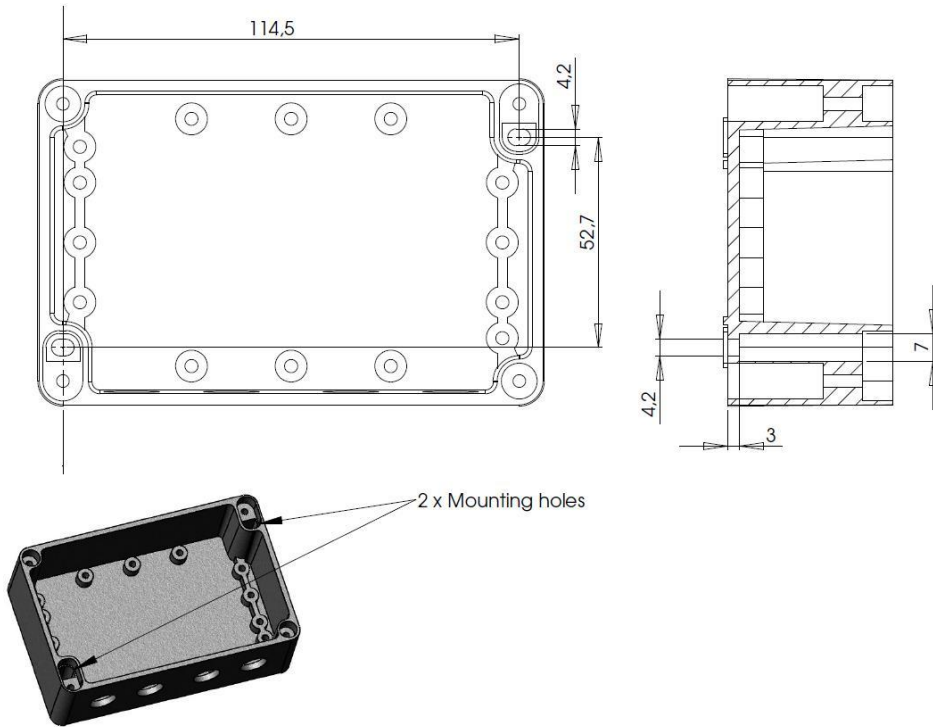

WIO Integrated (WIOI) dimensions in mm

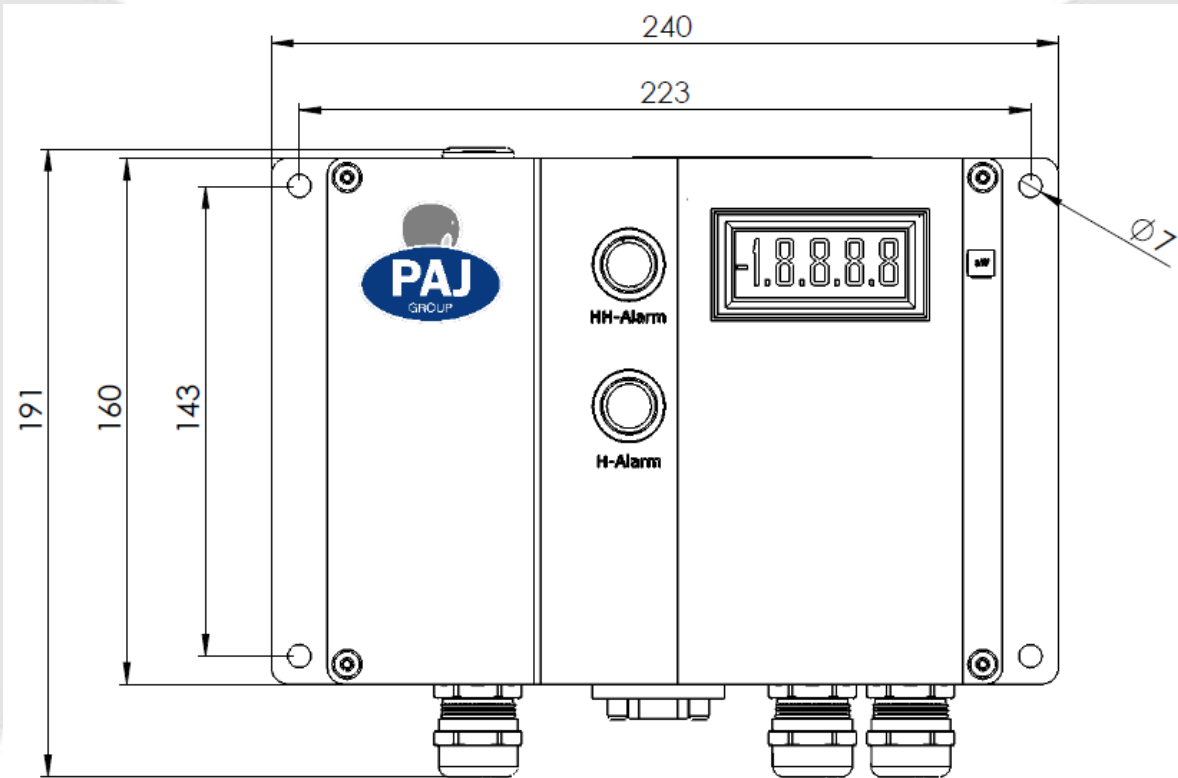



WIOI Sensor, short pipe, 1/2" thread, dimensions in mm:

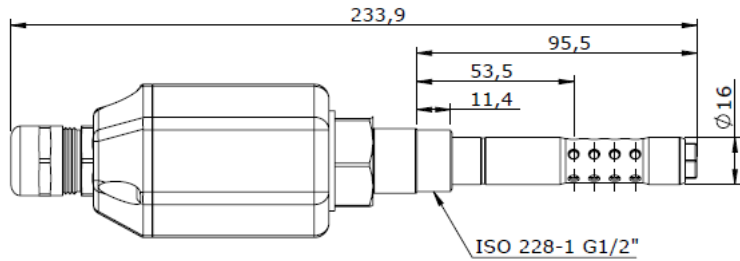
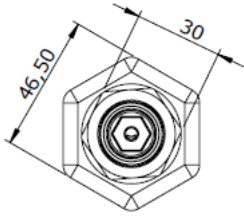

WIOI Sensor, long pipe, 1/2" thread, dimensions in mm:

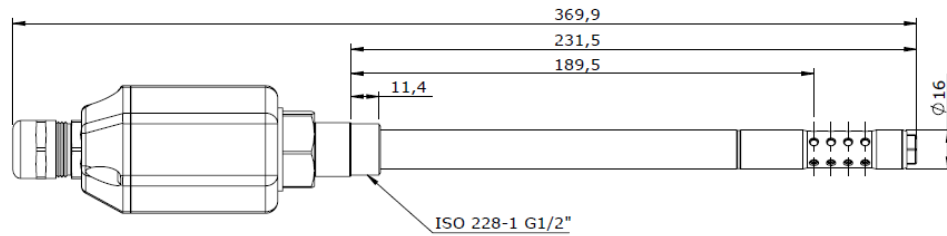
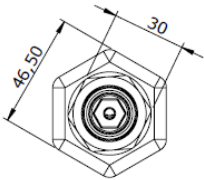

WIOI Sensor, long pipe, 3/4" thread, dimensions in mm:

